

A M E R I C A N   B A D M I N T O N   A S S O C I A T I O N



1971 - 1972

G U I D E S ,   R U L E S   A N D   R E G U L A T I O N S

H A N D B O O K

1971 -- 1972

GUIDES, RULES, AND REGULATIONS  
of the  
AMERICAN BADMINTON ASSOCIATION

USE THESE GUIDES ALONG WITH THE CURRENT ABA RULES BOOK

<u>TABLE OF CONTENTS</u>	<u>PAGE</u>
ADMINISTRATION	1
Personnel	1
Rules, Regulations, & Policies	1
Official Publications	1
Members	3
ABA Pins	4
ABA SECRETARIES	5
ABA TREASURER	10
AMATEUR STANDING RULES	12
Definition	12
Expenses	12
Prohibited Activities	12
Reinstatement	12
Interpretation	12
APPEAL TO EXECUTIVE COMMITTEE OR BOARD OF DIRECTORS	13
AWARDS	15
ABA Emblems	15
ABA Pins	15
ABA Trophies	16
Special Awards	17
Ken Davidson	17
United Savings Helms Hall of Fame	20
Players' Appreciation	20
BADMINTON USA, OPERATING PROCEDURES	21
FILM LIBRARY, ABA	26
FINANCE COMMITTEE	29
INTERNATIONAL BADMINTON	31
National Championships	31
Laws of Badminton	33
ABA Delegate to the IBF	34
ABA International Competition Guidelines	36
Devlin Cup	37-A
JUNIOR ACTIVITIES	38
Junior Awards	38
Junior Thomas and Uber Cup Teams	38
National Junior Championships	39
Other Junior Tournaments	40
Ranking	41



NATIONAL ABA BADMINTON NEWS COMMITTEE	42
RANKING	43
Administrative Procedures	43
Ranking Lists, Method of Making	43
Eligibility	44
Committee Responsibility	45
SHUTTLECOCKS APPROVAL AND ADOPTION	46
Approval for Tournament Play	46
Adoption for National Championships	47
Request for Bids	48
TOURNAMENTS & EXHIBITIONS	50
Championships	50
Exhibitions	50
National Championships	51
Sanctions	57
Actual Conduct of Tournament	59
Seed and Draw	60-A
ABA Match Scheduling	61
<u>APPENDIX</u>	
ABA CONSTITUTION	(1)
OFFICERS OF THE ABA: 1936 to Present	A
AWARD RECIPIENTS:	
United Savings-Helms Hall of Fame	B
Player Appreciation	B
Kenneth R. Davidson	C
DONORS OF PERPETUAL CHALLENGE TROPHIES	D
ABA CHAMPIONS:	
Junior:1947 to Present	E
National:1937 to Present	F
SAMPLE FORMS:	
Membership Applications	a
Tournament Entry Blank	c

INDEX

-----

The following items, formerly found in this Handbook, are now in the ABA Rules Book:

- Duties of Referees, Umpires & Linesmen
- Team Point Systems
- Picture of Service Fault

-----

Rankings from 1947 to the present are available upon request from the Administrative Secretary.

## ADMINISTRATION

### I. PERSONNEL

A. The ABA Board of Directors, Officers and Committee Chairmen (See ABA Constitution) are responsible for carrying out the policies and rules of the ABA and the IBF, and reporting the results of votes on matters of general interest to ABA members through mailings to associations, independent clubs and groups, and individual members.

B. Each ABA Director is elected by vote of all members living within the Region to be represented by the elected Director. Directorships for each of the six Regions are determined on the proportionate basis of total paid ABA membership in the Region as of Dec. 30, the current year.

C. The Officers (President, First Vice President, Second Vice President, Secretary and Treasurer) are elected by the Directors. The Officers, with the addition of the Immediate Past President, make up the ABA Executive Committee. The President, Secretary and Treasurer may be reimbursed (at the lowest published rate) for round trip travel only to ABA Board meetings.

D. Chairmen of Constitutional and Special Committees who are appointed by the President with the approval of the Directors carry out their respective responsibilities and report annually to the membership. Committee members' expenses will be paid by the Treasurer only upon receipt of bills having an approval of the Committee Chairman.

E. An Administrative Secretary is hired by the Board of Directors upon recommendation of the President. The Administrative Secretary is to maintain records, supplies, general correspondence, reports to members and others, and carry out general administrative responsibilities.

### II. RULES, REGULATIONS & POLICIES

A. Rules, Regulations and policies which govern ABA activities include those found in this Handbook and Annual Report as well as in:

1. International Badminton Federation (IBF) Rules And Regulations
2. ABA Constitution
3. ABA Articles of Incorporation
4. ABA Rules Book

B. Committees, the Board of Directors, and ABA Officers follow the rules and regulations as listed in this Handbook and the above publications in their efforts to work for the better promotion of badminton in the USA.

### III. OFFICIAL PUBLICATIONS

A. ABA Bulletins are published from time to time by the Executive Committee of the ABA and are distributed to every player in member associations and clubs and individual members of the ABA. Bulletins contain working information of primary interest to ABA members.



B. ABA HANDBOOK (Guides, Rules & Regulations), first published as a loose leaf book in 1952, contained all of the official rules and regulations of the ABA as well as historical facts of interest as to winners of competition and awards made each year. This present HANDBOOK is reprinted each year. Distributed without charge to: Past ABA Presidents; Current ABA Directors, Officers, Committee Chairmen; and Association Presidents, Secretaries and Treasurers; and Member Club Presidents or Independent Club and Group Contact Person. It sells for \$2.00 and may be ordered from the ABA Administrative Secretary:

Mrs. Virginia B. Lyon  
1330 Alexandria Drive  
San Diego, CA 92107

C. BADMINTON USA is the Official Magazine publication of the ABA. It is published a minimum of four times a year and may be obtained for \$3.00 a year (\$3.25 in Canada and \$3.50 Overseas) from:

Miss Bea Massman  
333 Saratoga Road  
Buffalo, NY 14226

D. The OFFICIAL RULES BOOK is printed by the ABA. It contains the IBF Laws of Badminton, many valuable hints on playing, handling tournaments, and interpretations of laws.

1. Copies of the Rules Book may be secured for 25¢ each (25 or more copies, 20¢ per copy, all postpaid) from the Rules Book Chairman:

Mr. Lester Hilton  
15 Tanglewood Drive  
Cumberland, RI 02864

2. ABA Rules may be copied in their entirety in publications, provided a complete copy of the printed material is submitted to the ABA Rules Committee and that a statement be included in the publication under the heading of "ABA Rules" stating that, "Although these are the rules as to this date, these rules may change from year to year to some extent, hence, anytime after (publication date), to insure yourself you are dealing with an up-to-date rule, secure the latest rules from the ABA Administrative Secretary."

E. IBF PUBLICATIONS

1. IBF HANDBOOK is published each year in England. It may be obtained for 10 Shillings (\$1.50) from the Honorary Secretary of the IBF:

Mr. H.A.E. Scheele  
4, Madeira Avenue  
Bromley, Kent, England



The IBF Handbook contains the names and addresses of all of the affiliated associations; the names of the officers of the IBF and the affiliates; the names of the title holders of all championship events of all nations from the inception of such events; and the results of all international matches. It also contains the regulations of the IBF with reference to:

International Badminton Championships: Thomas Cup for men and Uber Cup for women  
 International Badminton Federation Organization  
 International Matches  
 National Tournaments  
 Professionalism  
 Laws of Badminton and Tournament Regulations

2. Badminton Gazette, 6 issues yearly, is \$1.20 per year. The official outlet for IBF news, it may be obtained from:

The Badminton Gazette  
 24 The Charter Road  
 Woodford Green, Essex, England

#### IV. MEMBERS

A. A badminton Club affiliated with the ABA shall have a minimum of six (6) adult members. A badminton Association affiliated with the ABA shall have a minimum of four (4) clubs.

B. Applications for membership may be secured by writing to the Administrative Secretary. Samples of applications for association, club, or individual membership in the ABA may be found in the appendix of this book. Dues for the badminton season (July 1 -- June 30) are \$1.75 per adult player, (Amended April, 1971) \$1.00 per student or junior player in ABA Member Clubs and Associations; \$5.00 for Individual ABA Membership (Obtained directly through the ABA Administrative Secretary), which includes a subscription to BADMINTON USA; and a Life Membership, awarded for a contribution to the USBEF of \$100 or more, which membership also includes the BADMINTON USA subscription. Student and Junior Individual Memberships of \$1.00 are available from the Administrative Secretary for those not belonging to an ABA affiliated club, and will entitle students and juniors to participate in any and all ABA sanctioned tournaments, provided local tournament regulations are observed and fees are paid.

C. Reports to Members: The Administrative Secretary of the ABA sends information as to important items submitted to the ABA Board to the president and secretary of each Association, Independent Club member president, and individual member at the same time it is mailed to the Directors. This is for the information of the members and guidance in making suggestions to the Directors of the ABA before a vote is taken on such matters. After the vote, a report of the Directors' action on such matters is sent to the above same named persons.



V. ABA PINS

A. The Official ABA Pin is to be given to each Thomas Cup and Uber Cup team member picked to represent the USA, the team Coach, and the ABA President. Regardless of the number of times a player is chosen to represent the USA on the Thomas Cup or Uber Cup team, only one pin will be given to any one individual.

B. A "Give Away Pin" may be given in quantity, as determined by the Executive Committee, to players who take part in any International Matches to exchange with players and others at the matches.

C. A pin is available that any member of the ABA may buy for himself, to wear or give away as gifts. Such pins and a price list may be obtained by writing to the Administrative Secretary of the ABA.

ABA SECRETARIESCONSTITUTIONAL SECRETARY & GENERAL ADMINISTRATIVE SECRETARY

I. Constitutional Secretary, appointed by the President and confirmed by the ABA Board of Directors, shall:

A. continue to be a member of the Executive Committee and the Board of Directors of the ABA, and, whenever present, act as the recording officer if at Annual Meetings of the ABA and at any meetings of the Board of Directors;

B. send out agendas and ballots (as set up by the President) for Directors' Meetings and receive ballots as voted by the various Directors, and report thereon, to the President and, whenever appropriate, to the Executive Committee;

C. delegate the above responsibilities to the General Administrative Secretary at any time he (or she) wishes.

II. The appointment of a General Administrative Secretary shall be made by the Board of Directors (or by the Executive Committee if the Board of Directors so wishes) from any applicants for the position. The Treasurer of the ABA and the Constitutional Secretary of the ABA, as well as others, are to be eligible to hold the position.

A. An annual salary of \$1,250.00 (including travel expenses) shall be paid the General Administrative Secretary.

B. If not already a member of the Executive Committee through holding another office, the General Administrative Secretary shall serve as an ex-officio member of the ABA Executive Committee.

C. The duties of the General Administrative Secretary shall be basically to act as the Central Headquarters for the ABA and to perform such of the following as the Executive Committee may specify as to any fiscal year:

1. Be a source of all general information on badminton and supplies for ABA members and the public.

2. Carry out all general correspondence promptly:-  
 a. With ABA officers, Directors, Committee Chairmen and members,  
 1) Keep a record of names and addresses of all Committee Members and notify all appointees of their appointments,  
 2) Keep the general membership informed of Executive Committee and Board of Directors considerations and actions,  
 3) Obtain committee chairmen reports for interim and annual reports, acting as a liaison



between Committees and the ABA President, receiving reports from activity heads and also receiving requests from them for action by the President and the Executive Committee, and transmit copies of the foregoing to the President and, whenever appropriate, to the members of the Executive Committee.

4) Keep Committee rules up-to-date for the ABA Handbook published each August.

5) Maintain up-to-date membership files on all classes of ABA membership through reports (from the Membership Committee or otherwise) of names and addresses of Member Associations, Member Clubs and Non Badminton Groups, and Individual ABA Members, with current Presidents, Secretaries and Treasurers of Associations, Clubs and Groups, along with Club membership lists including current addresses for the master mailing list to be used for the ABA Bulletin and other such mailings.

a) Work with whoever is doing the print-out cards for the master ABA mailing list.

b) Furnish the master list, or any parts thereof, from time to time for such legitimate purposes as approved by the Directors or at the discretion of the Administrative Secretary.

b. Correspond with the IBF and Foreign badminton associations.

1) Make an Annual IBF report on forms supplied during the year by the Honorary Secretary of the IBF.

2) Distribute IBF Handbooks and other IBF materials and letters as received.

3) Serve as the direct contact between the ABA President and other national badminton organizations.

4) Deal directly with the Honorary Secretaries of badminton associations in other countries in any inter-country negotiations such as Thomas and Uber Cup and other team competition.

c. Maintain general correspondence with public and organizations outside of the ABA such as:

- 1) Schools
- 2) Advertisers
- 3) Interested individuals
- 4) Industry
- 5) Publications
- 6) Etc.

3. Order and maintain general supplies and distribute



them when requested to do so,

- a. Paper supplies including ABA letterhead and envelopes, mimeograph materials, copier supplies, and report forms.
- b. Current Publications:
  - 1) Annual ABA Report, Handbook, and Directory printed each August,
  - 2) ABA Match Scheduling,
  - 3) ABA Rules Books,
  - 4) Badminton Bibliography sheets,
  - 5) General ABA information sheets,
  - 6) Membership materials,
  - 7) Badminton USA,
  - 8) ABA Bulletins,
  - 9) ABA Rankings, 1947 to the present,
  - 10) Others.
- c. Awards:
  - 1) Championship emblems for Junior and Adult National Championships,
  - 2) Thomas Cup, Uber Cup, President, and Secretary emblems,
  - 3) Pins,
  - 4) Trophies:
    - a) Ken Davidson Keeper Trophies for both Junior and Adult -- also supply ballots for the Ken Davidson award vote at both tournaments if requested to by the tournament chairmen,
    - b) Due to excessive repair costs for the Perpetual Trophies, winners may no longer keep the trophies during the year. The Perpetual Trophies are to be kept by the Tournament Chairmen of the current championships. They are to have them all properly engraved according to ABA rules (See Awards), and sent on to the respective chairmen of the National Championships for the ensuing year.
    - c) Keep insurance up-to-date on all ABA Perpetual Trophies.
  - 5) Ranking Certificates.
- d. Membership supplies:
  - 1) Annual Membership cards for club use,
  - 2) Individual Membership cards,
  - 3) Thank-you letters to be used when dues are paid,
  - 4) Membership application forms for: a) clubs,
  - b) Associations, c) Non-Badminton club groups,
  - d) Individuals,
  - 5) Dues notices and follow-up reminders,
  - 6) Club roster forms for current listings and names to be deleted and addresses to be changed,
  - 7) Ballots whenever necessary,

Amended April, 1971



- 7) Club Roster information forms,
- 8) Current Club Roster and ABA Directory,
- 9) Individual member and club contact address master file,
- 10) Master, computer mailing list.

e. Fund Raising items:

- 1) Jewlery
- 2) Racket Covers
- 3) Publications
- 4) Others

4. General Responsibilities:

a. Centralize as much of the ABA activity as possible to avoid duplication of effort and expense as well as to provide better service to ABA members and others interested in badminton.

b. Do as much of the clerical work as possible for all ABA officers and committee chairmen to free them for the policy making and organizational portions of their positions.

c. Carry out the following responsibilities of the Constitutional Secretary if so requested to do so by the President or the Secretary:

- 1) Prepare, send ballots to the Board of Directors, and record results, reporting the final count to the President,
- 2) Prepare the agenda and proxy forms for the Directors' and Annual Meetings,
- 3) Take minutes at any of the regularly called meetings,
- 4) Transcribe, duplicate meeting minutes, and send to the appropriate people.
- 5) Send a summary of meeting activities to Badminton USA and ABA Bulletin editors,
- 6) Prepare the "Calls" to Board of Directors' and Annual Meetings.

d. Maintain the Permanent ABA Files.

e. Prepare the Annual Report, Handbook, and Directory from committee reports and Board action:

- 1) Committee Reports should be requested to be in by July 1,
- 2) Forward any request for action from Committee Chairmen or Activity Heads to the President and the Executive Committee or other appropriate persons,
- 3) Request all responsible persons to be sure that the material to be used is current and up-to-date,

4) See that every Past ABA President, ABA Officer, committee chairman, director, association president, secretary, and treasurer, independent club president and non-badminton group member representative receives a current copy.

5) Make extra copies to be available at \$2.00 each to interested persons.

f. Act as liaison between the National Championships Tournament Committee and the ABA with regard to the National Tournaments.

5. Balloting:

a. Observe the ABA Constitution requirements for the election of Directors, officers and approval of Presidential appointments;

b. Prepare and mail ballots for any Constitutional amendments in accordance with Constitutional provisions for such amendments.



ABA TREASURER

The ABA Treasurer shall:

1. Receive all monies coming into the ABA directly such as:
  - a. Dues from associations, clubs, groups, individual members, and students and juniors
  - b. Special Thomas Cup, Uber Cup and other fund raising drives
  - c. Tournament Sanction Fees
  - d. Funds from National Championships Committee for USA Players' travel
  - e. Others
2. Pay all ABA bills after vouchers, with substantiating bills attached, have been approved by the President;
  - a. Committee bills must be approved by the Committee Chairman before being submitted to the President.
  - b. Vouchers shall be supplied to all who may be needing them. With each payment of expenses being reimbursed, a new voucher will be included.
3. Pay annual general expenses that have been approved by the Board of Directors or the Executive Committee such as:
  - a. IBF Dues
  - b. IBF ABA representative's travel allowance
  - c. Administrative Secretary's compensation
  - d. Badminton USA subscription for each Individual ABA membership
  - e. Annual Corporation fee (Form comes to George Brown, Chicago, Il)
  - f. Travel allowance of USA players to US Nationals
  - g. Travel allowance of President, Secretary, and Treasurer to ABA Board Meetings
  - h. Perpetual trophy engraving and shipping expenses
  - i. Ken Davidson Keeper trophies
  - j. Trophy insurance (every three years)
  - k. Others
4. Make financial reports:
  - a. An interim report for the Annual Meeting,
  - b. Final report to be included in the Annual Report,
  - c. Interim or special reports to the President, Board, Finance Committee, or others who may request them or should have them, (Example- Thomas and Uber Cup Committee Chairmen),
  - d. Final financial statement to be used in filing income tax statement (ABA is tax exempt, but must file an annual statement),

5. Prepare, with Finance Committee help, and submit to the Board of Directors for approval, an annual budget for the ABA:
  - a. Notify committee chairmen from time to time as to their budget standings as well as requesting suggestions from them as to the amounts that will be needed by their committees for the coming year;
  - b. Re-evaluate the budget at mid-year, making whatever changes that seem necessary.
6. Maintain accurate account records of income and expenses for the ABA's many account categories:
  - a. Badminton USA and Rules Books (Rules Books account was transferred to General Funds Account, October, 1970) maintain their own accounts, but their reports are to be included in the total ABA financial report,
  - b. Special accounts may be set up when necessary.
7. Make deposits, withdrawals, and maintain records for all ABA bank accounts except BADMINTON USA:
  - a. General Checking and Savings,
  - b. Ken Davidson Savings,
  - b. Thomas and Uber Cup Savings,
  - d. Others
8. Serve as a member of the ABA Executive Committee and the ABA Board of Directors.



AMATEUR STANDING RULES

- I. DEFINITION: Any badminton player is an amateur who:
  - A. Does not receive, or has not received within 12 months since requesting reinstatement as permitted in sub-paragraph 2. hereof, below, directly or indirectly, pecuniary advantage by the playing of the game. In this connection, the phrase "playing of the game" shall not be construed as including teaching, coaching, or demonstrating the game as a physical education instructor or professor or recreation director at a school, college, university, or recreation department or facility -- all of which categories envisioned in this sentence shall be permitted activities.
  - B. Having lost his amateur status under 1. has been reinstated by the Amateur Status Committee of the ABA.
- II. EXPENSES: It shall be permissible to accept money for expenses in, or traveling to and from a sanctioned tournament or exhibition of the ABA if receipt of said funds is not in violation of the rules of the IBF.
- II. PROHIBITED ACTIVITIES: A player will have been considered to have forfeited his amateur status if he engages in the following acts:
  - A. Enters a competition open only to professionals;
  - B. Plays for a money prize or gate receipts. Interpretation: It shall not be considered playing for money or gate receipts if a player receives "merchandise order" voucher or the merchandise itself.
  - C. Plays in a tournament, team or exhibition match where professionals play or where gate receipts are charged, unless permission to hold such match has been obtained in advance from the National Tournament Committee or from an Association member under the jurisdiction of which such event is to take place.
- IV. REINSTATEMENT: Upon forfeiture of amateur status, any player may request the Amateur Status Committee for reinstatement and the Committee, upon evidence satisfactory to it, may so reinstate the player after a twelve month waiting period.
- V. INTERPRETATION: Any construction made by the Amateur Status Committee of the ABA as to the meaning, effect or application of any of the rules of amateur standing shall be binding upon all concerned, subject only to appeal under Section 5 of Article VIII of the Constitution of the ABA.



APPEAL TO THE EXECUTIVE COMMITTEE OR BOARD OF DIRECTORS

The procedure to be followed: Any ABA member desiring to appeal under Article VIII, Section 5 of the Constitution shall notify the Administrative Secretary of the ABA and accompany the notice with a statement of the facts involved, together with such supporting data and statements of reasons as he desires to submit, indicating to whom he is appealing.

1. Each party submitting materials to be forwarded by the Administrative Secretary, as set forth below is required to supply the same in sufficient number to send one copy to each of the respective parties entitled to receive the same as set out above.

2. A copy of such statements and reasons shall, as soon as possible, be sent air mail by the Administrative Secretary to:

- a. Each member of the body to which the appeal is taken;
- b. Each member of the Committee whose decision is appealed from;
- c. The other party, or parties to be affected by the decision.

3. The members of the committee whose decision is appealed from and the other party affected by such decision shall have ten days from the date of such mailing by the Administrative Secretary such answer as it is desired to submit in response to the statements referred to in paragraph 1.

4. Upon receipt of such answering material, the Administrative Secretary shall send a copy thereof to:

- a. The member body which has taken the appeal;
- b. Each member of the body to which the appeal is taken.

5. The member appealing shall have ten days from the date of such mailing of the answering material by the Administrative Secretary in which to file with the Administrative Secretary matter strictly in reply to that set up in the answer.

6. The Administrative Secretary shall, as soon as possible after receipt of such reply material, forward the same by Air Mail to the same persons mentioned in paragraph 2.

7. The matter shall thereupon be deemed to be submitted to the appeal body for decision.



8. The votes of the appeal body shall be mailed to the Administrative Secretary.

9. The decision of the majority of the appeal body shall be conclusive. In case of a tie vote, the decision of the committee shall be affirmed.

## AWARDS

Emblems, pins and trophies are awarded by the ABA to Champions, persons who have given outstanding service to the ABA as players or administrators. (See Appendix for lists of recipients)

### I. ABA EMBLEMS

A. The Official Emblem of the ABA is that which appears on the cover of this book.

B. The Administrative Secretary is authorized to distribute emblems, with the appropriate designations as noted below, to those who are entitled to receive them.

#### 1. USA NATIONAL CHAMPIONS

a. Emblems will be awarded to all USA champions for each officially approved USA National Closed Tournament event won. An individual player will be awarded an emblem only for an initial championship in each event. Players who win in a subsequent championship, an event for which they have previously received an emblem, may, if they so desire, receive another emblem for that event by requesting it from the Administrative Secretary.

b. The embroidered designations on these emblems shall include "ABA Champion" and immediately below, that of the appropriate event designation as follows:

Ladies' Singles  
 Men's Singles  
 Ladies' Doubles  
 Men's Doubles  
 Mixed Doubles  
 Senior Doubles (for  
     both men and women  
     and mixed)  
 Senior Men's Singles



#### 2. USA NATIONAL JUNIOR CHAMPIONS

a. Emblems will be awarded to champions of each age class (18 and under, 15 and under, 13 and under) irrespective of the event won. A player will be awarded ONLY ONE emblem for winning one or more events in a particular age class regardless of the number of times he wins that event or events in the same age class in subsequent years.



b. The embroidered designation on these emblems shall include "ABA Champion" and immediately below that, the word "Junior". Different colored stars will designate the Champions' age class. Gold - 18 & Under, Blue - 15 & Under, Red - 13 & Under.

c. Any player winning or participating with another player in winning an official annual Junior Championships event will thereafter be entitled to wear the ABA Junior Champion emblem.

3. THOMAS CUP & UBER CUP -- The official emblems for members of the Thomas Cup or Uber Cup teams shall be "ABA Thomas Cup" or "ABA Uber Cup".

4. OTHERS -- The ABA President and Secretary are entitled to wear the ABA emblem upon taking office. The emblem shall be embroidered with the titles of "ABA President" or "ABA Secretary".

C. Players named to represent the USA in international badminton play other than the Thomas and Uber Cup teams will be provided an appropriate emblem.

## II. ABA PINS

Official ABA Pins are given only to the ABA President, the Coach and members of the Thomas Cup and Uber Cup squads picked to represent the USA. Only one pin will be given to any one individual regardless of the number of times he serves as a player on a Thomas Cup or Uber Cup team.

## III. ABA TROPHIES

A. Perpetual Trophies of the National Junior Championships and Amateur Championships of the ABA:

1. The Executive Committee of the ABA shall constitute a Board of Trustees for the National Junior and USA Championships' perpetual trophies with power, subject to these rules and regulations, to make such arrangements and take such action as the Trustees may, from time to time, determine upon in connection with the continued safety of such perpetual trophies and all matters relating thereto.

2. Perpetual trophies shall be for annual competition in the events for which trophies shall have been given in the National Junior and USA Amateur Championships as arranged by the ABA. Competition for such trophies shall be restricted to fully qualified juniors and amateurs as prescribed by the ABA rules.

3. Perpetual trophies shall be of sterling silver and of such design as shall have been approved in each case by the Trustees. The Trustees shall have full authority to accept or reject, on any grounds they may determine, any offer made of a trophy or trophies for the National Junior or USA Amateur Championships.



B. Responsibility for Perpetual Trophies: Amended April, 1971

1. The Tournament Chairmen (Junior and Adult Championships) shall be responsible for the safekeeping of the trophies during the year preceding the subsequent National Championships.
2. The name of the winner(s) and the year shall be engraved in the proper place and in full conformity with the already established design and the bill for the engraving submitted to the ABA Treasurer for payment.
3. The chairman responsible for the trophies shall have them delivered in the shipping cases, prepaid, at least one month or sooner if requested to the site of the succeeding Championships. Upon receipt of the shipping bill by the ABA Treasurer, the sender will be reimbursed.

C. In the event that no National Junior Championships or USA Amateur Championships is held within 13 months after the close of the preceeding Championships, the parties responsible for the trophies shall contact the ABA Administrative Secretary as to where the trophies should continue to be stored. (Amended April, '70)

D. Engraving: Official wording for all trophies awarded at National Championships shall be:

1. Juniors -- "AMERICAN BADMINTON ASSOCIATION NATIONAL JUNIOR CHAMPIONSHIPS"
2. USA AMATEUR -- "AMATEUR CHAMPIONSHIPS OF THE AMERICAN BADMINTON ASSOCIATION"

IV. SPECIAL AWARDS -- See Appendix for recipients.

A. Davidson, Ken: Memorial Awards

In honor of Kenneth R. Davidson, the ABA in 1955 initiated the Annual Ken Davidson Memorial Award. It is



awarded to one junior and one adult\* player in this country who is adjudged to have contributed the most to badminton, and whose sportsmanship, attitude, and achievement best exemplify the spirit of badminton held in such high esteem by Ken Davidson, himself.

1. Rules for selecting the winners of the Ken Davidson Memorial Trophies:

a. The Kenneth R. Davidson Junior and Adult\* Memorial Trophies shall be awarded annually, in accordance with these rules, at the Junior and Open Amateur National Championships, respectively, by the appropriate Selection Committee, to the player in each Championships who is determined to have made the greatest contribution to the game of badminton, through his or her sportsmanship, or in other ways, either during such Championships, or otherwise.

b. Appointment of the Committees: With respect to each of the National Championships, at, or prior to the time thereof, the President (or such person as shall have been designated by him to make the appointment) shall appoint a Selection Committee composed of persons in attendance at such Championships (two of whom shall be players entered in such Championships). The Chairman of such committee shall be the President of the ABA if in attendance, otherwise, the Chairman shall be such person in attendance as shall have been appointed by the President (or shall have been appointed by the person designated by the President as aforesaid to make the appointment). The Committee shall have, in addition to the Chairman, four other members with wide acquaintance with the players, and, so far as practicable, from different sections of the United States.

2. Eligibility

a. No person shall be eligible for selection unless he or she shall be a bona fide contestant in the Championships at which the selection is to be made.

b. In the case of each trophy, any person who has previously been awarded such trophy shall thereafter be ineligible for such trophy.

3. Nominations

a. The Committee shall, at some appropriate time during the course of the Championships, announce that nominations are in order and shall designate the form which such nominations shall take and the method by which they shall be communicated to the Committee.

-----  
\* The Word "Adult" is used throughout this book replacing the word "Senior", now used to designate former "Veteran" events.



Such announcement shall also include a general statement of the factors to be considered by the Committee in determining the winner. Names of previous winners should be listed in the printed program.

b. In the event that the Committee deems it advisable to poll the contestants, such poll shall be taken by written ballot and all contestants mentioned in such balloting shall be nominees. In the event a ballot is used, it is suggested that it be substantially in the following form:

BALLOTKENNETH R. DAVIDSON MEMORIAL TROPHY

The trophy is awarded annually to the player in these Championships who is determined to have made the greatest contribution to the game of badminton, through his or her sportsmanship or in other ways, either during these Championships or otherwise.

The Selection Committee, which is charged by the ABA with making the award, asks that every contestant assist them in making the selection. While the results of this balloting are in no way binding upon the Committee, your ballot will be given considerable weight by the Committee in reaching its decision.

TO THE COMMITTEE: I wish to nominate \_\_\_\_\_

as the person best qualified for the Kenneth R. Davidson Memorial Trophy for the year \_\_\_\_\_.

Please return this ballot prior to the start of the closed semi-finals.

c. At the discretion of the Committee, nominations may be made, not only by contestants, but by any person actually in attendance at the Championships, and the Committee may nominate additional contestants at its own discretion.

4. Time of Selection and Award: <sup>Closed</sup> Selection shall not be made prior to the semi-finals of the Championships, but shall be made prior to the finals and the selection shall be announced and the award made at an appropriate time during the course of, or immediately following the final matches.

(Note: A small trophy that may be kept by the winner is provided by the ABA each year from a special Ken Davidson Trophy fund.)

B. Helms Hall of Fame Plaque <sup>(1)</sup> See Appendix for recipients

1. The purpose of this award is to honor an individual for achievement in the sport of badminton. Measures of achievement are generally considered as: excellence in play, sportsmanship, helpfulness to others, and cooperation.

---  
 Note (1) In the fall of 1970 The United Savings Bank combined with Helms to perpetuate the Sports Hall of Fame under the new name of "United Savings - Helms Hall of Fame".



United Savings- (1)

2. The Helms Hall of Fame is a private enterprise in Los Angeles, California, honoring outstanding athletes in many fields. The actual award is made by the Directors of the Helms Hall of Fame Foundation. The ABA merely selects a candidate for the Helms Foundation approval.

3. Recommended Selection Procedure: The following rules will not be binding upon the Selection Committee, but are to be used as a guide in their selection of a nominee each year.

a. Eligibility shall be limited to past and present USA National Champions in any event, or members of the USA Thomas Cup or Uber Cup Teams. (In case of close decisions only, contribution to the game may be considered as a determining factor, but playing ability, ordinarily, will be the primary factor in all selections.)

Only in cases of truly outstanding administrative contribution to the game, and at the discretion of the Helms Hall of Fame Selection Committee, a person may be nominated who does not qualify in the general eligibility of excellence of play as described above.

b. Recipients of the award must be citizens of the USA or have been a permanent resident at the time they qualify under paragraph a. above.

c. Insofar as is possible, the Committee shall consist of five former recipients of the Helms Hall of Fame award, including the Chairman, and be geographically distributed as to represent all major areas of the USA.

d. Selection shall be made by a majority of the five votes and the selection need not be unanimous.

e. No more than one selection shall be made in any one year except under unusual circumstances.

4. Reporting the Committee's selection: The final selection of the Committee shall be mailed to the ABA President, who shall forward the selection to the Executive Committee for concurrence. Upon receipt of concurrence from the President, the Selection Committee Chairman shall submit the selection to the Board of Directors of the Helms Hall of Fame Foundation. The selection shall be held in strictest confidence at all times by the members of the Selection Committee and the Executive Committee. Agreement is necessary before the submission to the Helms Board of Directors. Such agreement shall be carried out before the Annual Meeting of the ABA.

C. Players' Appreciation Award -- Established in 1966. Each year, by vote of a players' committee, a silver cup is awarded to someone they feel, as a non-tournament player, has done the most for badminton. See Appendix



OPERATING PROCEDURES  
FOR  
BADMINTON USA

1. Badminton USA is an official publication of the American Badminton Association (hereinafter referred to as the ABA), the former being a component part of the latter.
2. The Editorial Staff shall consist of the Editor of Badminton USA and the President of the ABA, with the assistance of an advisor to said Editor, which advisor shall be approved by the Editor.
3. Each season each Regional Association shall appoint a reporter whose duty shall be to submit to the Editor any and all items of news or other matters of interest pertaining to his or her region. These appointments shall be made on or before July 31st. The Editor shall choose any other correspondents and reporters.
4. The Editor shall have the power, authority, and obligation to:
  - a. edit all articles and material submitted for publication, except material submitted by the President, which material is to be included in full and without change;
  - b. subject to the other provisions of this working agreement, determine the content of each issue of Badminton USA;
  - c. proof read and mock up;
  - d. receive and record subscriptions;
  - e. furnish a copy of the Badminton USA mailing list to the ABA President on request and at the ABA's cost;
  - f. deposit all receipts in a Badminton USA bank account and pay all bills by check;
  - g. arrange for the printing of the magazine;
  - h. determine and prescribe advertising rates;
  - i. arrange for the addressing and mailing of the magazine, (Second Class mail shall be used); and
  - j. abide by the Post Office regulation that once a year the magazine contain a statement of ownership as called for by Act of October 23, 1962, Section 4369, Title 39 U.S. Code.
- In the event there is any difference of opinion between the Editor and the President in connection with the subject matter or wording of any published material, or otherwise, the decision of the President shall control.
5. Each season a minimum of four (4) issues of Badminton USA shall be published, the first such issue to be published as early as possible in the fall of each year. Whether or not there shall be additional issues published shall be determined by discussion between the Editor and the President each year.
6. The Editor shall be entitled to receive from gross revenue in connection with Badminton USA an amount equal to \$50 per issue thereof plus an amount equal to 50% of the gross receipts



over and above other expenses in connection therewith.

7. The Advertising Manager of Badminton USA shall be appointed by the Editor and shall be entitled to receive an amount equal to 10% of the advertising income he brings in to Badminton USA, including rework.

8. The balance of any profit shall be annually deposited in a Badminton USA savings account and the Editor may draw on it from time to time. The remainder to be considered the ABA share of profits, but to be held in the Badminton USA account and drawn on for ABA Badminton USA requirements, such as Individual Member subscriptions, advertising and promotion.

9. On or before July 5<sup>th</sup> of each year, the Editor shall render to the President of the ABA a full accounting for the year July 1st-June 30th immediately past, in such a form as shall be agreed upon, from time to time, by the Editor and the ABA President.

10. The cost (including postage) of free copies of the magazine (distributed for publicity, instructional, educational, or promotional purposes) shall be paid by ABA through deduction from the portion of profit going to the ABA provided always said "free" list shall be subject to the prior approval of the Executive Committee of the ABA, and provided also that if there is no such profit the ABA Treasurer shall pay the necessary amount therefore upon receipt of the annual accounting provided for in paragraph 9 above.

11. With respect to any badminton tour, or other commercial activity concerning badminton, conducted by any group other than the ABA, no issue of Badminton USA prior to the tour or other commercial activity shall contain any write-up or mention of such tour or other commercial activity concerning badminton, except as a paid advertisement. All tours or other commercial activity concerning badminton shall be entitled to equal advertisement opportunity. After completion of any tour or other commercial activity as to which there has been any such paid advertisement, the first convenient issue of the magazine thereafter may contain a story or write-up concerning the tour or other commercial activity concerning badminton.

12. It shall be the policy of the magazine:

a. not to publish "Letters to the Editor" or articles criticizing (1) the ABA, (2) any ABA proposal or functioning, (3) any matter relating primarily to the ABA, or (4) any individual ABA officer, or Director, the Executive Committee, or any Committee Chairman or Committee Member, without first submitting such letter or article to the person or Committee involved and giving such person or Committee the opportunity to reply in the same issue of the magazine;

b. not to publish the results of any tournament until and unless it has been sanctioned by the ABA;

c. to publish each year the rankings as soon as possible after submission thereof by the Ranking Committee, such publication to state that the rankings as published are subject to the approval of the Executive Committee and that if there is any question concerning the correctness of any ranking, reasons for a suggested change should be forwarded to both the Chairman of the Ranking Committee for



the consideration of his Committee and to the President of the ABA for the consideration of the Executive Committee.

13. Each subscription shall be on an annual basis, starting immediately after the first issue each year and ending with the first issue of the next year. Bills or notices of lapse of subscription shall be mailed by the Editor each year after the first issue in the Fall of such year to all 100% Member Clubs and individual subscribers except those subscribers who are Individual Members of the ABA. The ABA Administrative Secretary shall assume responsibility for the notification and billing of those who are ABA Individual Members in such year and for sending to the Editor \$2.00 for each such member, the same to be sent to the Editor the first of each month. The ABA Administrative Secretary shall also furnish the Editor with a list of ABA Life Members (whose subscriptions are to be automatic) and an aggregate amount equal to \$2.00 for each ABA Life Member shall be paid by the ABA through deduction from the share of profits going to the ABA, provided always that if there are no such profits, the ABA Administrative Secretary shall pay the necessary amount therefor upon receipt of the annual accounting contemplated in paragraph 9 hereof, and provided also that each year, as the second issue is sent to the post office for mailing, the Editor shall furnish the ABA President with a list of names and last known addresses of those persons, firms, groups or corporations who have subscribed the prior year but failed to renew the subscription.

14. Member Clubs which subscribe for 100% of their membership shall be entitled to the rate of \$2.00 per member.

15. Other subscription rates shall be as follows:

United States	\$3.00
Outside United States	\$3.50

16. The duties of the Advertising Manager shall be as follows:

a. In July, or earlier, of each year the Advertising Manager shall collect the names and addresses of current, past and prospective advertisers for the four (or more) issues to be published for the badminton season starting around October of each year.

b. He shall prepare a memorandum for the foregoing which memorandum shall contain as much pertinent information as possible, including, but not limited to such items as circulation, dates of issue, average number of pages of the magazine, deadlines for advertising copy, types of printing and rates.

c. On or about August 1st of each year a letter shall be written to all prospective advertisers who have never advertised in Badminton USA, soliciting their business. There shall be enclosed with this letter a copy of the latest issue of Badminton USA. If these prospective advertisers have offices in the city where the Advertising Manager lives, a personal contact shall be made whenever possible. At the same time a letter shall be written to all current advertisers, soliciting their continued business, which letter shall



enclose a copy of the memorandum prepared for prospective advertisers. Also, at the same time a letter shall be written to all past advertisers who have since dropped their advertisements, asking their consideration to once again advertise in Badminton USA. There shall be enclosed with this letter a copy of the memorandum prepared for prospective advertisers.

d. Thirty days after the letters, referred to in (c) above have been written, a follow-up letter shall be written to all such advertisers who have not agreed to advertise in Badminton USA by that time.

e. The advertising deadline for each particular issue of Badminton USA is usually the second Friday of the month immediately preceding the month of publication. As soon after this date as possible, but no later than two business days after the deadline set, the advertising copy shall be delivered to the printer for setting. The printer shall be requested to set the copy and send proofs to the Advertising Manager for proof-reading and such corrections as may be necessary. When these advertising proofs are received by the Advertising Manager, such corrections, if any are required shall be made and the proofs immediately returned to the printer. At this time the Advertising Manager shall advise the Editor of the number and size of all advertisements for the issue at hand.

f. After the printer has prepared the publication, he shall send six copies of the magazine, in tear-sheet form, to the Advertising Manager for billing purposes. The Advertising Manager shall enclose with an appropriate invoice to each advertiser, or his agent, three tear-sheets of the advertisement of said advertiser.

g. When payment is received by the Advertising Manager from an advertiser, or his agent, he shall make a record of the amount billed, the amount paid and the date on which it was paid. Advertisers are requested to make their checks payable to "Badminton USA", but if the advertiser, nevertheless, makes the check payable to the Advertising Manager, he shall endorse the check over to "Badminton USA". These checks shall be delivered to the Editor weekly.

h. If an invoice remains unpaid for 30 days, a second notice shall be mailed to the advertiser, and at this time, if an agent is to make payment for the advertiser, then a copy of the second invoice shall be sent to the advertiser.

i. The advertising Manager shall keep records of all money expended for postage and long distance telephone calls, which calls shall be made only when absolutely necessary.

j. Throughout the season, as additional names of possible advertisers become known to the Advertising Manager, he shall contact these possible advertisers in an effort to secure their advertising business for Badminton USA.

k. After all monies for the final issue are collected (usually about June 15) the Advertising Manager shall prepare

a summary record for the Editor, containing an accounting and all important facts for the previous season.

1. The Advertising Manager's commission, as provide in paragraph 7 above, shall be paid to him by the Editor after all advertising bills have been paid for the year--usually around June 15<sup>th</sup>. The Advertising Manager shall be entitled to be reimbursed for monies expended for postage and long distance phone calls, provided a record of the same is kept as provided in sub paragraph (i) above.



ABA FILM LIBRARY

The ABA Film Library began its first season of circulation in the fall of 1970. A catalog of films and order blanks are available from the Film Committee Chairman or the ABA Administrative Secretary. Fees for the rental of the films consist of postage, insurance, and a nominal charge to build up a repair fund. The circulation schedule is set up so that each film will be sent on to the next rentor throughout the season, returning to the librarian only in the summer or for repairs.

(a) Catalog for 1971-72 included here.

## SERIES N - U.S. CHAMPIONSHIPS

- N - 1. 1960 U.S. Open Amateur Championships, Chicago, Ill. (Reel 1).  
 Silent, 7 inch reel (approx. 12 min.). \$3.00 rental  
 Finals: Ladies' Singles: Margaret Varner<sup>(1)</sup> vs. Judy Devlin<sup>(2)</sup>  
 Men's Singles: Tan Joe Hok vs. Charoen Wattanasin.  
 (Indonesia) (Thailand)
- N - 2. 1960 U.S. Open Amateur Championships, Chicago, Ill. (Reel 2).  
 Silent, 7 inch reel (approx. 12 min.). \$3.00 rental  
 Finals: Senior Men's Doubles: Wynn Rogers & Fred Serafin  
 vs. Wayne Schell & Harold Seavey.  
 Men's Doubles: Finn Kobbero (Denmark) & Charoen  
 Wattanasin (Thailand) vs. Jim Poole & Manny  
 Armendariz.  
 Mixed Doubles: Judy Devlin Hashman & Bunky Roche  
 vs Finn Kobbero & Margaret Varner Bloss.  
 Ladies' Doubles: Judy Devlin Hashman & Sue Devlin  
 Peard vs. Dorothy O'Neil & Margaret Varner Bloss.
- N - 3 1964 U.S. Open Amateur Championships, San Diego, Calif.  
 Silent, 7 inch reel (approx. 12 min.). \$3.00 rental
- Opening ceremonies, with flags and full court view.  
 Selected rallies from matches featuring Joe Alston, Wynn  
 Rogers, Jim Poole, Dick Mitchell, Carl Loveday, Bill  
 Berry, Russ Lyon, Pat Gallagher, Torben Kops (Denmark),  
 Oon Choong Teik (Malaysia), Eichii Sakai (Japan), Wayne  
 MacDonnell (Canada), Raul Rangel (Mexico), Manuel Odorica  
 (Mexico), Margaret Barrand (England), Chanarong  
 Ratanasaengsuang (Thailand). Portions of:
- Finals: Ladies' Singles: Tyna Barinaga vs Dorothy O'Neil.  
 Men's Singles: Channarong Ratanasaengsuang vs.  
 Jim Poole.  
 Men's Doubles: Joe Alston & Wynn Rogers vs. Jim  
 Poole & Mike Hartgrove.  
 Ladies' Doubles: Tyna Barinaga & Caroline Jensen<sup>(3)</sup>  
 vs. Lois Alston & Doris Haase.
- Trophies presented by Dr. Dave Freeman

(1) now Bloss (2) now Hashman (3) now Hein



- N - 4. 1969 U.S. Open Amateur Championships, Northwestern State College, Natchitoches, La. Silent, 12 inch reel (approx. 40 min.). \$5.00 rental

Semi-finals: Ladies' Singles: Pernille Hansen Kaargard (Denmark) def. Eva Twedberg (Sweden) 6-11, 11-8, 11-8.  
 Men's Singles: Rudy Hartono (Indonesia) def. Ippei Kojima (Japan) 15-6, 15-13.  
 Mixed Doubles: Erland Kops (Denmark) & Judy Devlin Hashman def. Ng Boon Bee (Malaysia) & Retno Koestijah (Indonesia), 15-12, 7-15, 15-8.

Finals: Men's Singles: Rudy Hartono def. Muljadi (both from Indonesia) 15-9, 15-12.  
 Men's Doubles: Ng Boon Bee & Gunalan (both from Malaysia) def. Kojima (Japan) & Channarong Ratanasaengsuang (Thailand) 15-3, 15-7.  
 Ladies' Singles: Miss Minarni (Indonesia) def. Pernille Hansen Kaargard 11-1, 11-2.  
 - - - -

#### SERIES I - INSTRUCTIONAL

- I - 1. Fundamentals of Badminton, presented by All-American Productions; technical assistant, Jim Poole. Sound, 7 inch reel (approx. 12 minutes). \$3.00 rental

This film features Jim Poole, Wynn Rogers, Rod Starkey, Manuel Armendariz, Beulah Armendariz, and Helen Tibbetts. They demonstrate correct court positions, forehand and backhand grips, and footwork; and they display proper form for the forehand clear, backhand clear, forehand drive, and round-the-head stroke, forehand drop, backhand drop, net drop, and forehand smash. Both left and right handed form is shown. Various drills for practicing these skills are demonstrated. Finally, a few of the finer points of play are discussed in observing actual play.

- I - 2. Badminton - Educational "Sports Techniques." An Athletic Institute Educational Loop Film, 1959. Super 8 continuous loop film in cartridge: must be run on a loop film projector (Technicolor makes a good one, many schools have them). Silent. Consultant: Dr. James L. Breen. Demonstrators: James L. Breen, Janette D. Breen, James R. Poole, Margaret Varner Bloss. There are thirteen (13) loops. \$10.00 rental

Loop C-1: Grip and Cocking  
 C-2: Footwork  
 C-3: High Deep Serve  
 C-4: Low Short Serve



- C-5: Drive Serve
- C-6: Flick Serve
- C-7: Forehand Overhead - Defensive & Attacking Clears
- C-8: Forehand Overhead - Smash & Drop Shots
- C-9: Backhand Overhead - Defensive & Attacking Clears
- C-10: Backhand Overhead - Smash & Drop Shots
- C-11: Drive Shots and Underhand Clear
- C-12: Net Shots
- C-13: Around the Head Shots.

- - - - -

FILM LIBRARY REQUEST FORM

1. Each film may be kept Wednesday through Sunday and must be mailed to the next destination by Monday morning. Thus, please request dates corresponding to Wednesday through Sunday.
2. Fees consist of the rental fee listed with each film in the catalog, plus postage to the next destination.
3. Please mail request and fees to Dr. Stan Hales, 1421 Niagara, Claremont, CA 91711.
4. If all the dates that you request are taken, you will be given an alternate date and notified.

	FILM	DATES		
		1st CHOICE	2nd CHOICE	3rd CHOICE
1.	_____	_____	_____	_____
2.	_____	_____	_____	_____
3.	_____	_____	_____	_____
4.	_____	_____	_____	_____
5.	_____	_____	_____	_____

Rental Fees enclosed \$ \_\_\_\_\_

NAME \_\_\_\_\_

ADDRESS \_\_\_\_\_

CITY \_\_\_\_\_ STATE \_\_\_\_\_ ZIP \_\_\_\_\_



FINANCE COMMITTEE

Each year a Finance Committee shall be appointed by the Executive Committee composed as follows: The President of the ABA, the Treasurer of the ABA, and not less than one or more than three other persons, as determined upon by the Executive Committee, such other members to be persons other than the Secretary or any Vice President of the ABA and at least one of such other members to be an experienced investment or banking person, and the following procedure shall be followed for centralizing the ABA funds:-

1. As early as possible in each fiscal year, after consulting with those who are in charge of the various ABA activities, the Finance Committee shall determine how much working cash reserve is needed by each such activity to have on hand which would take care of current expenditure needs in their ordinary course of operation. The amount of this reserve, which is in the nature of a petty cash fund should be kept as low as possible. After such determination, any excess funds which are separately held by such activity at the time are then to be remitted to the Treasurer upon his request. A separate ledger account is to be kept by the Treasurer for each such activity, but the Treasurer is to hold the same as part of one or more composite investment portfolios, invested in savings accounts or otherwise. Anytime special provisions are made for any ABA activity covering financial arrangements for said activity, these regulations shall not apply.
2. Whenever the initial working cash reserve of an activity is depleted to less than 50% of the working cash reserve specified as hereinbefore indicated, the activity head may, at his or her election, obtain from the Treasurer such amount as will restore the working cash reserve to its original specified total amount.
3. As to each activity, whenever, through receipts from sources other than the Treasurer, the amount of funds separately held by such activity exceeds by more than 25% the original total amount of the working cash reserve specified for such activity as hereinbefore indicated, the activity head is promptly to remit such excess to the Treasurer.
4. As to each activity, whenever further funds over and above the aforementioned working cash reserve are needed by such activity, a request therefor is to be made to the Treasurer, and after such request has been referred to the Finance Committee for its recommendation, there is to be furnished by the Treasurer to, or for the benefit of, the particular activity such amount of further funds as is authorized by the Executive Committee. The manner of furnishing these funds for the benefit of the activity is to be in accordance with whatever the Treasurer and the activity head decide upon as being best under all of the then circumstances.
5. The Finance Committee is to advise the Treasurer as to the investment of ABA funds.



6. The Finance Committee is also to make recommendations to the Executive Committee regarding the maximum amount (but not the application thereof) which in its opinion, from a financial viewpoint, would be available for use during the current fiscal year for special expenditures, such as salary and expenses of the General Administrative Secretary.

7. Consideration should be given to having a composite investment portfolio covering funds held for international competition, whether for Thomas Cup or Uber Cup purposes, but without any consolidation being affected except for such investment purposes.



INTERNATIONAL BADMINTON

- I. The ABA, along with some 58 other national associations, make up the membership of the International Badminton Federation (IBF) with headquarters in London, England. It is through meetings with representatives of these national associations that the Laws of Badminton for national and international play are established.

The rules listed here are some of those of primary interest to players and groups planning any international competition. For more details, all of the Laws may be found in the IBF Handbook.

II. NATIONAL OPEN CHAMPIONSHIPS

A. Any tournament of the status of a national open amateur championship (i.e., not restricted to the players of the country concerned) shall be subject to the following regulations: --

1. The Tournament must be under the direct control of the national organization of the country in which it is held.
2. Only one such tournament may be held annually in any country
3. The title and dates of the Tournament must be sanctioned by the Tournament Committee of the IBF, and every application shall be made in writing to conform to the following requirements:
  - a. for a tournament desired to be held between October 1 and April 30, application must be made by the preceding May 31.
  - b. for a tournament desired to be held between May 1 and September 30, application must be made by the preceding September 30.
4. Two or more tournaments in the same continent shall not be sanctioned for the same date without the special consent of the Council of the IBF.
5. No player shall be eligible to compete unless he or she is a bona fide amateur, and is a member of a club affiliated to an organization in membership with the IBF. (Individual ABA membership is acceptable in this case.)
6. International specification for the court
  - a. The height of a court for international competitive play shall be a minimum of 26 feet or 8 meters from the floor over the full court. This height shall be entirely free of girders and other obstructions over the area of the court.



b. There shall also be at least four (4) feet or 1.25 meters clear space surrounding all the outer lines of the court, this space being also a minimum requirement between any two courts marked out side by side.

7. Shuttles

a. Modified shuttles, as permitted under Law 4, shall not be used without the consent of the organizations concerned.

b. One brand of shuttle only must be adopted for exclusive use during the Tournament, and the name of this brand must be advertised in the prospectus.

c. No rationing of shuttles per match must be allowed and all shuttles used must be a charge against the Tournament and not a charge against the players concerned.

B. Invitations to Foreign Players: Any tournament or exhibition match, to which it is desired to invite players from another country to compete, shall be subject to the following regulations:

1. The national organization of the promoting authority shall notify the national organization of the club to which the player shall belong when issuing the invitation.

2. No player shall participate in any tournament or exhibition match promoted or organized by any individual or business house interested in the manufacture or sale of badminton equipment. Violation of this regulation shall result in immediate suspension of amateur status.

3. For the purpose of these regulations, a player's national organization shall be that to which the club, of which he or she shall have been an active playing member for the three months immediately preceding, shall be affiliated, and in the country in which he or she shall for the time being, be resident, and this shall be quite irrespective of the player's qualifications for international matches. (ABA accepts Individual ABA Membership in lieu of club membership.)

C. Qualifications for International Players

1. ABA Thomas and Uber Cup Committees are instructed, when selecting a team to represent the USA in competition for the respective Cups, to take into consideration as an important factor, whether the respective players have been entrants in the National Championships of the ABA held prior to the time of selection, without, however, hereby making participation in such a national championships an absolutely inflexible requisite condition precedent for selection regardless of all other circumstances.



2. A player shall be qualified to represent a nation provided that he or she shall have:

a. for the three months immediately preceding the date of the fixture concerned, been a bona fide member of the association affiliated directly or indirectly to the IBF;

b. been born in, be a citizen of, or become a naturalized citizen of the country concerned, or shall have resided therein for two years immediately preceding the fixture concerned. Any question as to the interpretation or operation of this regulation shall be determined by the Executive Committee of the IBF whose decision shall be final.

3. When once a player has represented a nation, he or she will, subject to regulation 2.a. above, always be eligible to represent that nation and no other, except that, always subject to 2.a. above:

a. if two years shall have elapsed since a player last represented a nation, he or she will be eligible to represent any other nation for which he or she might then be qualified;

b. in the case of a woman, she shall upon marriage, be eligible immediately thereafter to represent the nation to which she may thereby accept citizenship and likewise, on dissolution of such marriage by death or otherwise, she may immediately revert to her last previous qualification, provided that she may not represent more than one nation in the same season.

4. A player shall be deemed to have represented a nation if he or she shall have been officially nominated to represent that nation and shall have accepted such nomination.

5. If a player shall have represented a nation and such nation is subsequently divided into two or more nations or is absorbed by another nation, either politically or by recognition of the IBF, such player shall, for the purpose of these regulations, be deemed, from the date of such alteration, not to have represented any nation.

D. National Championships Draw and Seeding: The ABA has adopted the recommendations of the IBF for all sanctioned ABA tournaments. Rules regarding the Draw and Seed are to be found under the chapter on Tournaments and Exhibitions.

III. LAWS OF BADMINTON (PLAY): The ABA Rules Book may be ordered from the Rules Book Chairman for 25¢ each.



THE ABA DELEGATE TO THE IBF

Each IBF affiliated national organization, such as the ABA, is entitled to appoint not more than two delegates to represent it at the Annual General Meeting (AGM) of the IBF. If both delegates attend the AGM, both may participate in the deliberations and discussions, but only one delegate may cast the votes to which the national organization is entitled.

The AGM of the IBF is held in London every summer on a Tuesday either the last week in June or the first week in July. The ABA receives the official notice of the AGM along with a form that is to be returned to the Hon. Secretary of the IBF with the name(s) of the designated delegate(s) who will be attending the meeting. The privilege of membership in the IBF means more than just contributing an annual fee or levy; it carries with it the obligation to be an active and useful participant in the process of decision making on rules and regulations affecting the game and its players. If the ABA wishes to play an active role in the councils of the IBF, it must recognize that this objective can only be achieved through individuals who are willing and able to attend the meetings of the world organization --- either as a delegate to the AGM or as a member of the Council if elected to that body.

On the occasion when neither of the appointed delegates is able to attend the AGM, a special effort must be made to secure a substitute. The most desirable solution is to enlist the services of a knowledgeable official or player in England who is willing and able to accept the designation of the representative of the ABA. This type of arrangement is a perfectly workable way for a national organization to secure representation at the AGM when there is no citizen of the country who can travel to London for the occasion. However, the ABA should strive to show its face at these important meetings as often as possible. If an emergency arrangement should become necessary at any time, its success will depend upon taking action on it as early as possible, maintaining full communication with the substitute delegate and transmitting appropriate instructions for voting on those proposals on the Agenda which the ABA wishes to take a specific position. If any emergency action is necessary to maintain the ABA position through substitute representation, the best course is to communicate promptly with the IBF Hon. Sec.

The AGM of the IBF follows a pattern that changes little from year to year. The Council convenes on the following day for one of its three meetings per year -- to elect its committees and to consider matters that have been referred to it by the AGM. All resolutions or proposals to be considered by the AGM must have been submitted to the IBF Hon. Secretary in writing at least 4 months prior to the date of the meeting. All such proposals are printed in the Agenda and circulated in advance to all the member national organizations and their appointed delegates.



The total representation at the AGM usually numbers 40 persons. The conduct of the meeting is strictly in accordance with the rules of parliamentary procedure. Many of the matters acted on by the meeting are decided by a visual tally of votes, each organization using a paper flag marked with the number of votes that may be cast for their national body, but such matters as the election of officers and members of the Council are handled by secret written ballots.

The Council of the IBF is, in effect, the Executive Committee of the IBF. Election to membership in this body implies obligation to attend its meetings whenever the member can arrange to do so. Operations of the IBF do not provide for balloting on any matters by mail. Opinions on matters on the Agenda for any meeting may be sent to the Hon. Secretary --- but, in order to have a part in any actions that are taken, a delegate to the AGM or a member of the Council must be present in person. The Council schedules three meetings a year. One taking place on the day following the AGM and the other two held in late March and early October, respectively.



INTERNATIONAL TEAM COMPETITION  
THOMAS CUP, UBER CUP AND OTHERS (1)

I. The object and purpose of participation in International Team competition including Thomas and Uber Cup by the American Badminton Association is to bring victory to our country and to develop our young players.

II. Responsibilities of the ABA: The President, with the approval of the Board of Directors, will appoint the Cup Committee Chairman and the Cup Coach. Great care should be taken in the selection of the coach. Factors to be considered are: past experience, proven ability, knowledge of the game, impartiality, and ability to work with and train a team. The coach should be non-playing, unless of unquestioned ability to make the team. The policies and procedures concerning finances and preliminary squad selection methods will be set by the Executive Committee of the ABA in consultation with the Cup Committee Chairman and Cup Coach.

III. Responsibilities of the Cup Committee Chairman: The Chairman prepares the budget for the Committee's operation annually and sets the methods for raising funds in consultation with the Coach and the Executive Committee. The Chairman is responsible for seeing that dates and sites are set for the ties, that the preliminary squad and teams are selected and that the competing teams are notified according to the IBF and other agreement regulations, that the IBF entry for Thomas and Uber Cup are filed on time by the ABA Executive Secretary, that the official clothing is purchased for the team and that travel arrangements are made for to team to get to the ties. The Chairman shall also keep the Committee members informed about these matters.

IV. Responsibilities of Committee Members: The members appointed by the Chairman (which must include the Ranking Committee Chairman and the Cup Coach) are responsible for raising funds and tie sites.

V. Coach Responsibilities: The Coach is responsible for the identification, training, selection, and coaching of players who will represent the ABA in international events (i.e. clinics, exhibitions, games, ties, etc.). In fulfilling the above responsibilities, the Coach will consider the players' growth potential, rankings, tournament participation, and tournament results. These factors, plus the Coach's subjective evaluation of the players' potential contribution as a team member will be the basis for nominating a player for an international event.

The Coach will have a Development Participation Statement on file from all players desiring to be considered for international events. (See sample Development Participation Statement, page 37-2). This statement will be reaccomplished annually, normally at the Nationals, but no later than 120 days following the Nationals. Prior to nominating a player for a specific event, the Coach will have on file an Event Commitment Statement (See sample Event Commitment Statement on page 37-3) indicating that the proposed

(1) Changes approved April 1971 to have the same Coaches for all International Competition, not just Thomas and Uber Cup.



nominee will be available and play in the selected event. The Coach will supply the Event Commitment Statement, which includes the details of the event, to the proposed nominees. The Coach will select the Captain of the team and will keep all players under consideration for a given event, the Cup Committee Chairman, and the ABA President informed on all major courses of action and decisions. The Coach's selection of the players for a given event is subject to the approval of the Executive Committee

VI. Players' Responsibility: Players desiring to be considered for participation in international events will file a Development Participation Statement (See Page 37-2) with the Coach. This statement places the following obligation on the player:

- A. Cooperation with the Coach and his or her policies;
- B. Practice and training on a year-round basis when possible;
- C. Participation in the Nationals;
- D. Coordination of tournaments, events and partners upon the request of the Coach;
- E. Play and coaching with younger players who show outstanding potential.

Note: Deviations or modification from the above general provisions will be coordinated with the Coach.

Players, upon the request of the Coach, will sign and return an Event Commitment Statement (See Page 37-3) indicating their availability or non-availability for a specific event. When this statement is verbally requested by the Coach, it will be followed up with a written statement.

VII. Tryouts: Tournaments are the principal source of competitive information available to the Coach, and are considered as tryouts. The Coach may schedule additional tryouts to obtain information on a specific individual or groups of players. Nine singles games plus several doubles matches per day of tryouts will not be considered excessive.

VIII. Right of Appeal: Any player who believes that he or she has been wrongfully by-passed for the team selection may appeal to the Executive Committee.

IX. Time for Naming the Coach, Squad, and Team: The Coach should normally be appointed to a three year term such that the third year would be a Thomas/Uber Cup year. The preliminary squad should be named a year or more prior to the expected dates of the tie. Should the preliminary squad be named a year or more prior to the tie, subsequent evaluations by the coach may be used to add new players to replace squad members. The Team selected for the tie must be announced at least ten days prior to the date of the tie. The same team need not be named for each tie. The Team should be named sufficiently in advance of the tie to give it time to make travel and clothing preparations.

X. Finances: For Regional Tryouts players must pay their own



transportation to the site. Tryout site will be requested to attempt to get housing for those players who wish it, but otherwise the players must take care of their own housing as well.

For National tryouts the following financial guidelines will prevail:

1. For those who live outside a 200 mile radius of the tryout site, the ABA will pay their air fare.
2. For those who live within the 200 mile radius of the tryout site, no financial allowance will be made.
3. The organizers at the tryout site will be requested to provide housing, but if unable to the players must house themselves.
4. No per diem is allowable.
5. Each player invited to the national tryout will receive three dozen shuttles.

For players selected to the team to play a tie the following financial guidelines will be observed.

1. Each player selected for the team will receive an additional dozen shuttles.
2. Each player selected for a tie will receive a per diem of \$10.00 per day starting on the day the Coach requests the players to arrive at the destination for the tie (for the day they actually arrive if they arrive after the Coach expects them to be there), and ending on the day the Coach expects them to leave the site of the tie, which is expected ordinarily to be the day following the completion of the tie.
3. Each person selected on the Team to play any particular tie shall be furnished housing at the tie and such uniforms as may be appropriate.



DEVELOPMENT PARTICIPATION STATEMENTDate

I, \_\_\_\_\_, understand the following conditions conditions and obligations and desire to participate in the Development Program. Participation in this program is understood to be a prerequisite to being selected as a member of the Thomas/Uber Cup Squad, Devlin Cup Squad and/or participant in any other events in which the ABA elects to be officially represented.

- A. Full cooperation with the respective Coach.
- B. Practice and training on a year-round basis whenever possible
- C. Participation in the National Championships.
- D. Coordination of tournaments, events and partners upon request of the respective Coach.
- E. Play and coaching with young players showing outstanding potential.
- F. Participation, if selected, as a member of the Thomas/Uber/Devlin Cup and/or other team designated to represent the United States. An "Event Commitment Statement" will be requested from each player prior to his/her being named to a particular team. This Statement will indicate the players availability to participate in the forthcoming event.

Deviations as indicated to the above may be requested from the respective Coach.

\_\_\_\_\_  
Signature\_\_\_\_\_  
Date\_\_\_\_\_  
Street\_\_\_\_\_  
City\_\_\_\_\_  
State\_\_\_\_\_  
ZIP\_\_\_\_\_  
Phone: Area Code - Number



Event Commitment Statement

Date: \_\_\_\_\_

If selected as a member of the \_\_\_\_\_  
Event's Name

I understand and agree to the following:

A. Location and Date of Event: \_\_\_\_\_

\_\_\_\_\_

B. Format of play: \_\_\_\_\_

C. Team makeup: \_\_\_\_\_

D. Inclusive Dates of Event: \_\_\_\_\_

E. Date players will be notified of their selection: \_\_\_\_\_

\_\_\_\_\_

F. Emergency procedures covering players who cancel participation after indicating their availability:

\_\_\_\_\_

\_\_\_\_\_

G. Transportation and Housing Accomodations: \_\_\_\_\_

\_\_\_\_\_

\_\_\_\_\_

H. Reporting date and times for players: \_\_\_\_\_

\_\_\_\_\_

I will be available to participate in the \_\_\_\_\_  
as described above. (Event Name)

Signature: \_\_\_\_\_ Date: \_\_\_\_\_

I cannot participate in the above event for the reasons noted on the reverse of this sheet.

Signature: \_\_\_\_\_ Date: \_\_\_\_\_



DEVLIN CUP

Mr. and Mrs. J. Frank Devlin donated a silver cup to be presented to the winning team of badminton competition between countries in North and South America. To date two such matches have been held. The first held in 1966 in Concord, between Canada and the USA, was won by the USA, 11-3. Competition was renewed in 1971 at a match held in Toronto, Ontario and won by Canada 4-3. To date only the two countries have competed. The following points have been agreed upon by the two countries for the organization and conduct of the international fixture.

1. The tournament shall be held every third year (non-Thomas and Uber Cup years) alternately in Canada and the USA.
2. The match shall be played each occasion on the last Saturday in January at a location which shall be determined in July of the preceeding year.
3. The team of each country shall consist of six or seven adult players. However, if junior players meet the qualifications for team selection for either country, it is permissible to include them.
4. There will be seven matches played in the following order: (a) two ladies' singles played simultaneously; (b) two men's singles played simultaneously; (c) one ladies' doubles; (d) one men's doubles; (e) one mixed doubles.
5. No player shall take part in more than two matches.
6. All players must qualify in accordance with Thomas and Uber Cup regulations respectively.
7. At least one month prior to each match, arrangements shall be made between the ABA and the CBA for delivery of the Devlin Cup to the host nation, unless the Cup is, at that time, already in the possession of the host nation. Cost of delivery shall be borne by the previous winner.
8. Each country shall be financially responsible for the transportation of its own players and officials to and from the site of the match. (The ABA will furnish a round trip airline ticket or direct expenses for transportation by private automobile for all its Team members. An estimate of such expenses should be submitted to the Coach one week before the match.)
9. All expenses incurred in the promotion and running of the match shall be the responsibility of the host country, including billeting of both teams. Maximum billetin allowable for the guest team shall be from Friday noon until Sunday noon. Private home billeting shall be acceptable.
10. Any and all profit which may be derived through advertising, sales promotion, gate receipts or other legal means in connection with the match shall be retained by the host country.
11. Both teams are to be named and communicated to the other country at least ten days prior to the match. Substitutions for illness or injury may be made prior to the start of play. The line-up for matches must be made the day prior to the start of play.
12. Shuttles shall be selected by the Official Referee, subject to Law 4 of the IBF Handbook.
13. The host country must suggest and send to the visiting country for its approval the name of the Official Referee.



## JUNIOR ACTIVITIES

- I. ALL JUNIOR ACTIVITIES are under the guidance of the ABA Junior Activities Committee. The ABA President, after receiving recommendations from member associations, shall appoint, with the approval of the Board of Directors, one member from each Member Association as members of the Junior Activities Committee. Recommendations of associations shall not be binding on the President. The Chairman shall be a member of the ABA Board of Directors.
- II. JUNIOR AWARDS
- A. ABA Emblems are awarded to winners in the National Junior Championships. See AWARDS.
- B. Perpetual Trophies are awarded to the winners of the National Junior Championships. See AWARDS.
- C. Each year an outstanding Junior is selected for the Ken Davidson Memorial Award. See AWARDS.
- III. JUNIOR THOMAS AND UBER CUP TEAMS
- A. To establish incentive for improving USA general standard of men and women's play, a National Junior Uber Cup Team and a National Junior Thomas Cup Team have been approved.
- B. It shall be one of the duties of the Thomas Cup and Uber Cup Committees to obtain the names of juniors and girls and boys up to the age of 21 years, within the areas which shall be designated under their control, to find adult players willing to take charge of junior squads and to help them to organize squad activity such as practices, coaching, matches, etc.
- C. Membership in the Junior Cup Teams will be determined as follows:
1. Eligibility qualifications will be the same as those for the Thomas Cup and Uber Cup Teams, as outlined in the IBF Handbook regulations, except that the players must be 21 years of age or under on April 30 of the season in which they are selected for the Team.
  2. The Junior Thomas Cup and Uber Cup Teams shall consist of six singles players and three doubles pairs. The selection of players may be such that some individuals may be selected for both singles and doubles. However, the maximum number selected for the team shall not exceed twelve girls and twelve boys.
  3. A girl or boy who has at any time been selected to play on the adult Cup Team will no longer be eligible for selection to the Junior Team.
  4. 5. The members of the Junior Cup Teams are to be selected in the following manner:
 

Juniors named to these teams will be asked to sign Development Participation Statements and Event Commitment Statements similar to those required of the adult team members. See International Competition. (Approved 4/71)



- a. Each association member is requested to organize a Junior squad for both boys and girls.
- b. Inter-Regional Tournaments or Trials are to be held from which Junior Cup Teams are to be selected by the Thomas Cup and Uber Cup Committees and the Junior Activities Committee and approved by the ABA Executive Committee.

#### IV. NATIONAL JUNIOR CHAMPIONSHIPS

##### A. Entitling and Entry Cards

1. The official wording for all announcements of the Junior Championships, their entry forms, their prizes, and other related materials and promotion shall be as follows:

"AMERICAN BADMINTON ASSOCIATION  
NATIONAL JUNIOR CHAMPIONSHIPS"

2. National Junior Championships Entry Card: The following statement shall be printed on each individual entry card, or form of the National Junior Championships.

"According to the Rules and Regulations of the  
ABA, of which I am a member (Card # \_\_\_\_\_)  
I am an amateur in good standing and  
am qualified to entry in this tournament.

(Signed by) \_\_\_\_\_ Entrant."

##### B. Time and Sponsors of National Junior Championships

1. The Annual Junior Championships shall be held in the spring of each year at such place and upon such dates as may be approved by the Executive Committee.
2. Applications from association or club members in good standing, desiring the allocation of the National Junior Championships tournament, should be filed in writing with the ABA President at least 60 days prior to the annual meeting next preceding the tournament desired.

##### C. Player Eligibility

1. Competition shall be restricted to ABA members who are amateurs in good standing, provided they have received their parent's or guardian's consent and have established their residence within the USA for one continuous year.
2. Competition shall be restricted to amateurs who are citizens of the USA or aliens having established their residence within the USA for one continuous year preceding the Championships Tournament.
3. Competition shall be restricted to the following three official classes (verified to the Jr. Activities Chairman by birth certificate or other certified proof):
  - a. 18 years and under: Competitors in this class shall be restricted to those who will not reach, or have not reached their 19<sup>th</sup> birthdays before October 1 of the season of the Championships.



b. 15 years and under: Competitors in this class shall be restricted to those who will not reach, or have not reached their 16<sup>th</sup> birthdays before October 1 of the season of the Championships.

c. 13 years and under: Competitors in this class shall be restricted to those who will not reach, or have not reached their 14<sup>th</sup> birthdays before October 1 of the season of the Championships.

4. Written medical release will be required by all participants in the National Jr. Championships.

#### D. Events and Scheduling

1. The following official events for all classes shall be included in the National Junior Championships:

Girls' Singles, Boys' Singles, Girls' Doubles,  
Boys' Doubles and Mixed Doubles

2. Subject to the approval of the ABA Executive Committee, the organization holding the National Junior Championships may eliminate any event.

3. The ABA Match Scheduling system of play (see Tournaments and Exhibitions) shall be used in conducting the Annual National Junior Championships.

#### E. Financial Responsibilities

1. Any surplus resulting from the operation of the Annual National Junior Championships shall be divided 25% to the Club operating the tournament, 50% to the ABA and 25% to the Association sponsoring the tournament.

2. In the event that an association should, of itself, operate a tournament, its participation in the surplus shall be 50%.

3. The ABA share of the surplus shall be allocated for the development of Junior Activities by the Junior Activities Committee, subject to the approval of the ABA Executive Committee.

### V. OTHER JUNIOR TOURNAMENTS

A. Sanctions: The policy of the ABA covering sanctions of tournaments and championships applies to all junior tournaments and championships. In the sanctioning of junior tournaments and championships, the same procedure shall be followed as in the case of adult tournaments and championships. (See Sanctions in chapter on Tournaments and Exhibitions)

#### B. Player Eligibility

1. It is the recommendation of the ABA that the age limits which apply to the National Junior Championships be followed in all junior tournaments and championships.

2. Players under 16 years of age must have the approval of the Junior Activities Committee and the Executive Committee of the ABA to take part in the National Amateur Championships. (In 1971, 18 & Under Singles winners were entered in the National Amateur Championships and their transportation (Round-trip) was paid by the ABA from Junior Activities funds.)



C. Results: Results of Junior tournaments and tournaments in which juniors participate shall be sent to the ~~ABA Ranking Chairman, who will see that~~ the ABA Junior Activities Committee receives them, to be included in the file of materials to be used as a basis for junior rankings. (Changes approved 4/71)

## VI. RANKING

A. The Junior Activities Committee shall establish junior rankings and maintain such records and files with sufficient data to properly establish accurate ranking of all junior players by the ABA.

B. The general procedure of ranking as contained in these regulations (See Rankings) for USA rankings of adults, will be followed by the ABA Junior Activities Committee in preparing the Junior Ranking Lists.

C. The ranking lists thus determined, with necessary notes and explanatory materials to properly support the ranking lists submitted, shall be forwarded to the ABA President not later than 90 days after completion of the National Junior Championships. The ABA President and Executive Committee, after review of the lists shall, if they so desire, approve the ranking lists.

D. Conditions to be considered in establishing Junior Rankings:

1. The official tournament season of the ABA during which results will be considered for ranking shall be July 1 through June 30.

2. Juniors having played in at least two sanctioned tournaments (Junior when possible, but in areas where there are not Junior Tournaments, then in adult tournaments), or have competed in the National Junior Championships of the current season.

3. No more than ten players or teams shall be ranked in the three age categories (See Junior Activities, C.3.) ONLY when there are sufficient statistics to substantiate such rankings.



NATIONAL ABA BADMINTON NEWS COMMITTEE

It shall be the function of this Committee to:

1. Disseminate news pertaining to badminton in general and to the ABA in particular to newspapers, magazines, official ABA publications, television, radio and other appropriate publicity outlets;
2. Furnish badminton information, results of National Championships, records and similar material to publishers of sports books, almanacs, encyclopedias, and similar publications;
3. Cooperate with local publicity persons to assist in getting the widest possible local coverage of badminton tournaments and events;
4. Cooperate with the chairmen of the adult and junior national championships in making available to them information and pictures that will assist in giving the widest possible publicity to the tournament;
5. Fulfill requests for general badminton information through the distribution of such literature as may be available for free general distribution by this Committee and refer specific information requests to the appropriate ABA officer or chairman;
6. Keep in communication with leading sports goods manufacturers and distributors to publicize and promote badminton to our mutual benefit;
7. Maintain a file of badminton information, records, and pictures suitable for promotional purposes;
8. Maintain contact with news and other sports oriented organizations to assure the widest possible badminton coverage;
9. Make available to all ABA committee chairmen, particularly International Cup Team Committees, information and pictures that will assist in the promotion of the activities of each committee;
10. Be prepared to carry on activities in the field of public relations that will carry the message of ABA activity to the attention of the widest possible number of people.

Suggested contacts may be secured from the Committee Chairman, Mr. Jack van Praag or from the ABA Administrative Secretary.



## RANKING

### I. ADMINISTRATIVE PROCEDURE

A. The official tournament season of the ABA during which results will be considered for ranking shall be July 1 through June 30 each year.

B. It shall be the responsibility of the Ranking Committee Chairman to collect the official tournament results from all tournaments sanctioned by the ABA, with the exception of Junior tournaments. The results of Junior tournaments and tournaments in which Juniors played an active part should be sent to the Junior Activities Chairman. When either chairman is unable to get tournament results, the Regional Chairman shall be contacted. If the Regional Chairman is unsuccessful, the President of the ABA should be notified that results can not be obtained. (Wording changed and approved April, 1971)

C. Ranking and Tournament Sanction Committee: It shall be the duty of this Committee to determine the National Ranking of players and report their findings to the Secretary annually ninety (90) days after completion of the National Championships (Adult). It shall also have authority to sanction all ABA recognized regional, sectional, state and local tournaments and exhibitions.

#### D. The Chairman shall:

1. Keep all members of the Ranking Committee informed on all ranking rules and the procedures to be followed;
2. Act as a clearing house for transmission of all opinions;
3. Prepare and submit to the Ranking Committee the record of each player and team to be considered immediately after June 30 so that the results will be ready in the required time;
4. If, after one round of Ranking Committee voting, the resulting ranking lists submitted do not reflect a majority vote for each ranking in a particular event, or events, the Chairman shall, at his discretion, and in order to speed up the work, forward his proposed ranking list to the Ranking Committee members. This list shall not carry a vote or be considered in any way binding on the Committee;
5. The Chairman shall break any tie vote which may occur after at least two rounds of voting by the Ranking Committee; A majority vote will then determine the ranking, which is then sent to the ABA Executive Committee for approval.

### II. RANKING LISTS

- A. Junior Rankings: See Junior Activities.
- B. Ten players or teams, no more, who are citizens or permanent residents of the United States (See III. B below) shall be ranked in the following categories ONLY when



there are sufficient statistics to substantiate such rankings:

Men's Singles	Men's Doubles	Mixed Doubles
Ladies' Singles	Ladies' Doubles	Sr. Mixed Doubles
Sr. Ladies' Doubles	Sr. Men's Singles	Sr. Men's Doubles

The Committee shall add a footnote, or a secondary list, to the regular ranking list which will set out the relative ranking of foreign players who have played in the United States during the current season, but who are not eligible for ABA ranking.

C. Players and teams who fail to make the Ranking List may be alphabetically listed under:

1. Honorable Mention: can be given to up to four (4) players or teams below the 10 ranked. If there are two #2's, the next ranking is #4 -- the only time more than 10 are ranked is if two are bracketed at #10. Honorable Mention is given to players or teams who are qualified for ranking and are theoretically #11, #12, #13, #14.
2. Insufficient Data: may be given to players or teams who do not qualify for ranking but who the committee feels are strong enough to warrant designation.

### III. ELIGIBILITY

A. Junior Eligibility: See Junior Activities.

B. In order to qualify for consideration for a National Ranking a player or team must:

1. Be a citizen or a permanent resident of the United States on July 1 of the current season. It shall be the duty of the Chairman to satisfy himself as to a player's eligibility. The permanent resident shall be a player who has been a resident for one year prior to July 1 of the season in which he or she is being considered for ranking. In other words, a player must be a resident for one year prior to the beginning of the season being used for ranking purposes. (Changed 4/71)
2. Have played in at least three sanctioned tournaments between July 1 of one year and June 30 of the following year; or in the case of Senior events only, have played in the Senior National Championships held during this period of time. (Changed 4/71)
3. Have reached the semi-finals of the National Championships to be considered for a "once only appearance" for a ranking over an established player or team.
4. All rounds of both the Closed and the Open are to be given the weight of two in ranking consideration.
5. Senior Mixed results are to be considered for ranking only if both players are 40 years old.
6. Entry into either the United States Closed or Open will count as one tournament each in the determination of eligibility for ranking. (Approved 4/71)



C. Only matches which are played at best two out of three games, round robins included, shall be considered in National Ranking. Tryouts and games of 21 points results shall not be considered. Scores from any foreign tournaments in which ABA members met each other or mutual opponents may be used.

D. Late season scores are to be given more weight than those in the early part of the season. (Changed 4/71)

E. A player may be ranked with more than one partner provided each team meets the necessary qualifications.

F. The Closed National Championships winners will become the National Champions, but not necessarily number 1 on the Ranking List.

G. Seeding for the National Championships shall follow the National Ranking list unless current information gives reason for exceptions which shall be used only with the approval of the ABA Tournament Championships Committee.

#### IV. COMMITTEE RESPONSIBILITY

A. It is the obligation of the Committee members to consider themselves as representatives of the ABA, a national organization, and not the guardians or advocates of players in a particular region.

B. Votes of the Committee shall be on an analysis of tournament results and scores and NOT a matter of opinion of relative play. Only when no direct wins or losses between two players or teams are available, shall scores against common opponents be considered.

C. Upon completion of the Committee's votes, the Ranking lists shall be submitted to the ABA Executive Committee for approval.

D. Ranking Certificates shall be awarded each year to each player whose name appears on the Ranking List. The event(s) in which the player is ranked shall appear in the Certificate. The Certificates shall be awarded within 30 days after the ABA Executive Committee approval of the Ranking List (Adults, not Junior List).



## SHUTTLECOCKS APPROVAL AND ADOPTION

The jurisdiction of the Shuttlecock Committee includes all matters pertaining to shuttlecocks necessary or advisable for the benefit of the ABA and the betterment of the games, so far as such jurisdiction is consistent with the Constitution of the ABA.

### I. APPROVAL OF SHUTTLECOCKS FOR TOURNAMENT PLAY

A. The ABA will advise all member clubs and associations that they must use only shuttles approved by the Shuttlecock Committee for tournaments sanctioned by the ABA.

1. A definite plan of approval shall be followed.
2. Approval shall be given annually, to be announced not later than July 1 of each year. Approvals may also be given during the year to any concern submitting a request for the same.
3. Notification to shuttlecock manufacturers or distributors of the award or rejection of approval shall be made by the Administrative Secretary of the ABA after a full report from the Committee.
4. A fee of \$25.00 shall be charged for any specifically named shuttlecock (Example: Tourney, Durex, Eagle, etc.) submitted to the Committee for testing which is subsequently approved by the Committee. Round or pointed feathers under the same brand name shall be considered as one brand.
5. The Committee shall approve only "For Tournament Play."
6. The Committee shall approve or reject each shuttle by brand name, regardless of whether the shuttles may be made by one manufacturer and submitted to it by one or more concerns.
7. No manufacturer or distributor shall be obliged to submit shuttles for testing and approval by this Committee.
8. Certain non-natural feather shuttles are approved for use in all tournaments except: (Adopted 4/71)
  - a. Adult "Open" tournaments for which a \$5.00 sanction fee is charged;
  - b. ABA Amateur Championships - Closed and Open;
  - c. USA National Junior Championships.
9. The grant of approval allows the concern to use the wording: "Approved by the American Badminton Association Shuttlecock Committee," for any publicity it may desire during the term of approval.
10. Any manufacturer or distributor granted this approval must agree not to ship to retail outlets any shuttles with advertising showing ABA approval after the expiration of the term of approval without written permission of the Committee.



11. Approval of a shuttlecock submitted by a concern shall not be effective until such concern shall have signed and delivered, to the Administrative Secretary of the ABA, an agreement in the form attached to these rules and regulations. Violation of such agreement or any infraction of these rules and regulations will warrant the ABA in recommending the non-use of the shuttlecock in question by associations, clubs and individual members of the ABA.

B. Form Of Agreement:

"The undersigned (name of manufacturer or distributor) having read and understood the rules and regulations governing the approval and adoption of shuttlecocks by the ABA, hereby, on consideration of the approval of the undersigned's shuttlecock (Name of Shuttlecock) by the Shuttlecock Committee of the ABA, accepts and agrees to the provisions of such rules and regulations now in effect, and also agrees with the ABA that the provisions of Rule 10 of said rules and regulations will be strictly complied with after the expiration of the term of such approval."

(Signed (Name of manufacturer or distributor))

By (Name of authorized person)

II. NATIONAL CHAMPIONSHIPS ADOPTION

A. After careful study of the question of rotation of the adoption, or open competitive bidding, the policy of open competitive bidding has been chosen.

B. The Committee shall give first consideration in its selection to those concerns who have been given approval. No shuttle rejected as suitable for "For Tournament Play" shall be considered in the selection.

C. The Committee shall issue a call for bids no later than October 1, and its report of selections shall be submitted to the ABA President not later than December 15.

D. The award of the adoption shall be made so that the concern chosen will be notified not later than January 1 of the year the Championships is to be held. Notification shall be made by the Administrative Secretary of the ABA. She shall notify all associations and club members of the name and brand of the shuttle adopted for each current National Championships as soon as the report of the selection is made by the Shuttlecock Committee.

E. The Committee is permitted to request from all concerns bidding that they submit whatever number of shuttles the Committee desires, free of charge. This amount shall not exceed one dozen to each member of the Committee, unless extra tests are found necessary.

F. The terms of the bid and award shall be as follows:



REQUEST FOR BIDS

TO ALL SHUTTLECOCK MANUFACTURERS  
AND DISTRIBUTORS:

Manufacturers and Distributors are hereby requested to make application for the official adoption of shuttles for the \_\_\_\_\_ National Badminton Tournaments. The Amateur Championships of the American Badminton Association will be held in the following locations:

---

---

Outlined below are the terms and conditions for adoption.

1. Bids must be received by \_\_\_\_\_, The companies chosen to supply the shuttlecocks for each tournament will be notified immediately thereafter.
2. The supplier agrees to pay the American Badminton Association \$50.00 for the adoption of its shuttle for use in either the Amateur Championships of the American Badminton Association or the United States Junior National Championships.
3. A set price of \_\_\_\_\_ per dozen or \_\_\_\_\_ per gross will be paid to the supplier for shuttles actually used in each Championships tournament.
4. At least three different weights, or flight, of shuttles must be on hand in sufficient quantities to meet all requirements throughout the tournaments for the estimated number of matches to be played. The selection of the weight or flight to be used will be subject to review repeatedly during play in accordance with standardized testing procedures as varying atmospheric conditions may dictate. All testing will be under the supervision of the tournament committee member in charge of properties and playing conditions.
5. Although it is not mandatory, it is advisable that the supplier have a company representative on hand, available to the Tournament Committee at all times to aid in decisions regarding the flight of shuttles to be used at particular times and to arrange that the proper quantities of shuttles are available to either the committee member in charge of shuttles or to the Official Referee as needed.

No supplier will be awarded the adoption of shuttles for both



tournaments except in the unlikely situation that only one bid is received by this Committee.

The supplier of the official shuttle adopted for each of the National Championships Tournaments shall be entitled to a prior right to a full page advertisement in the preferred or prominent location in the Official Program of such tournament at the supplier's expense.

Advice will be furnished later to the supplier whose shuttle is adopted for each tournament giving the name of the responsible member of the Tournament Committee who will supply details regarding the playing conditions, the anticipated atmospheric conditions, and the proper requirements for varying weights of shuttles.

Formal requests for adoption, including acceptance of the above terms and conditions and other necessary correspondence regarding such bids should be addressed to the undersigned and must be in the mail to be received by \_\_\_\_\_ .

Chairman ABA Shuttlecock Comm.



AMERICAN BADMINTON ASSOCIATIONAGREEMENT

The undersigned \_\_\_\_\_  
(Name of Manufacturer or Distributor)  
having read and understood the Rules and Regulations governing the approval and adoption of shuttlecocks by the American Badminton Association, hereby, in consideration of the approval of the undersigned's shuttlecock \_\_\_\_\_  
\_\_\_\_\_ by the Shuttlecock Committee of the American Badminton Association accepts and agrees that the provisions of Rule 11 of said Rules and Regulations of the American Badminton Association will be strictly complied with after the expiration of the terms of such approval.

(Signed) \_\_\_\_\_  
(Name of Manufacturer or  
Distributor)

By \_\_\_\_\_  
(Name of Authorized Person)

Date: \_\_\_\_\_



TOURNAMENTS & EXHIBITIONS

I. CHAMPIONSHIPS: The use of the word "Championships" in the title of a tournament shall be limited to tournaments restricted to the following players:

A. Those residing in the territory embraced within the scope of the title;

B. Those who are members of a member club of an association or associations for such territory of an individual ABA region.

C. The Tournament Committee of an association or club may make any further restrictions as it may see fit.

II. EXHIBITIONS:

A. Matches in the United States:

1. No Admission Charges: Exhibition matches in the United States where there is no admission charge may be carried out at any time without authority, except for any association special ruling within its own jurisdiction, and amateurs may play with or against professionals without restriction, except that amateurs shall in no way receive money or the equivalent in excess of actual traveling and living expenses incurred.

2. Admission Charged:

a. Exhibition matches in the United States where there is an admission charge, may be authorized by the ABA Tournament Committee when submitted and approved by the Association Member in the region where the proposed match is to be held, provided that the proposed match is to be conducted under the auspices of the ABA association member, an affiliated club, or a recognized and reliable organization. Each authorization of an exhibition match shall be expressly conditioned upon the following:

1) The responsible organization shall, if requested by the Tournament Committee, present the Tournament Committee a statement showing all amounts in money or the equivalent paid directly or indirectly to each amateur participating in such exhibition.

2) No amateur in such exhibition shall receive, in money or the equivalent, in excess of his actual traveling and living expenses incurred.

b. All of the foregoing provisions shall apply where there is an admission charge, whether the



matches are between amateurs only, or between amateurs and professionals, or matches in which both amateurs and professionals take part in any other manner.

B. Matches in Foreign Countries: Any player or players affiliated with the ABA may take part in exhibition matches in other countries, provided, in the case of each such match, that no amateur participating therein shall receive in money or the equivalent in excess of his actual traveling and living expenses incurred, and that either --

1. such match shall have been duly approved by the governing body, or by authority duly delegated by that body, of the country where such match is held, or
2. the participation in such match by such player or players affiliated with the ABA shall have been approved by the ABA Amateur Status Committee.

### III. NATIONAL CHAMPIONSHIPS (CLOSED-OPEN AMATEUR CHAMPIONSHIPS)

A. Entitling of National Championships (For National Junior Championships see Junior Activities)

The official wording for all announcements of the Championships of the ABA and the entry forms, annual prizes, and other related material and promotion of such Championships shall be as follows:

"AMATEUR CHAMPIONSHIPS OF THE AMERICAN BADMINTON ASSOCIATION"

B. Entry Card: The following statement shall be printed on each entry card or form of the Amateur Championships of the ABA:

"According to the rules and regulations of the National Badminton Association of \_\_\_\_\_  
I am a member in good standing."

(Signed by) \_\_\_\_\_ Entrant.

CERTIFICATION;

"I hereby certify that the above entrant is an amateur and a member of the \_\_\_\_\_  
Club \_\_\_\_\_,

holding membership card number \_\_\_\_\_ "

(Signed by Club Secretary) \_\_\_\_\_

"I hereby certify that I am an ABA Individual Member holding card number \_\_\_\_\_ "

\_\_\_\_\_  
Signature of Entrant



C. Operation of ABA Championships:

1. The Closed-Open Amateur Championships of the ABA (Hereinafter generally called "Championships") shall be held in the spring of each year, at such place as may be approved by the ABA Executive Committee, subject, when required, to the sanction of the IBF.
  2. Open-Closed Championships at the same meeting: A sponsor of an Amateur Championships of the ABA shall conduct a closed amateur championships at the same time and place as an open championships is conducted.
  3. No player shall be eligible to compete in the Championships unless he or she is an amateur according to the rules of the national association, other than the ABA, with which the player is affiliated.
    - a) Eligibility for Closed (Approved Oct. 1970)
      - 1) Must be a player who is an ABA member and
      - 2) either a United States Citizen, or
      - 3) a foreign player meeting ABA requirements for ranking.
    - b) Eligibility for Open Championships (Approved October, 1970)
      - 1) A non-United States Citizen who is a member of the IBF, or
      - 2) a qualifier through the United States Closed, or,
      - 3) invited by the Tournament Committee, subject to the approval of the ABA Executive Committee.
- Note: (Approved April, 1971)
- A. Direct entry into the Open is limited to those in item #b)1) and #b)2). Entry by way of #b)3) is only by way of invitation to either fill an existing vacancy or fill out the draw, and may only be made after the Closed Championships has progressed at least to the quarter-finals.
  - B. A foreign player eligible to play in the Closed under #a)3) above, may have the election of entering directly into either the Closed or the Open, but not both.
4. Limitation of the number of entries may be made only with the approval of the Board of Directors or the Executive Committee of the ABA, or pursuant to any rule or regulation hereafter adopted by said Board.
  5. Applications for the operation of Championships must be filed in writing with the ABA President at least 60 days prior to the Annual Meeting next preceeding the tournament desired. Such application may be made by an association member, a member club, or by any organization which is acceptable to the Executive Committee, provided, always, that any such application by an association affiliated club is sponsored by the



association of which the club is a member. Bid information should include:

- a) Proposed dates for the Championships,
- b) Location of play with an indication of the number of available courts and other playing facilities,
- c) Hotel and housing accomodation plans and costs,
- d) Name of Chairman,
- e) Group or groups sponsoring the Championships.

6. The Championships shall include the following official events:

- a) Men's Singles
- b) Ladies' Singles
- c) Men's Doubles
- d) Ladies' Doubles
- e) Mixed Doubles
- f) Senior Men's Singles
- g) Senior Men's Doubles
- h) Senior Ladies' Doubles
- i) Senior Mixed Doubles

7. Subject to the approval of the Executive Committee, the organization holding the Championships may eliminate any event.

8. Age Requirements:

- a) Players under 16 years of age will not be eligible to compete in the Championships without special approval of the Junior Activities Committee and the Executive Committee.
- b) The minimum age limit of each individual for the senior events is 40 years.
- c) The foregoing age limitations are effective as of the first day of the Championships.

9. IBF rules for Seed and Draw as published in the current ABA Rules Book and included in this Handbook shall be followed in setting up the Championships Seed and Draw, with the following Closed exceptions:

Approved October 1970. For USA Tournaments:

- a) Players from the same region should not play each other in the first round in singles or in doubles, if both players on each team are from the same region, unless there are insufficient entries to allow such action.
- b) (Approved February, 1971) In the case of an entry of 12 or more, but less than 16, there may be two (2) entries placed in addition to the two (2) seeded entries; and in the case of an entry of 24 or more, but less than 32 entries, there may be two (2) entries placed in addition to the four (4) seeded.
- c) (Approved February, 1971) A spot shall be held open in the Closed draw for the Junior Singles Champions. Should such junior player already



be entered, he will take the spot reserved for the National Champion and his spot becomes a Bye. If seeded or placed in the draw, the Junior Champion takes the seeded or placed spot and the spot reserved for the National Junior Champion becomes a Bye.

10. The ABA Match Scheduling System, included in this Handbook, shall be used in conducting the Championships.

11. Regulations for awarding ABA Emblems and Perpetual Trophies, (See Chapter on Awards).

12. "United States Player" as here used, means a player who is a member in good standing of the ABA and who, both at the time of the current Championships and at the time of the preceding Championships, is either a citizen of the United States or an alien who has established residence in the United States for a period of at least two years immediately preceding such Championships. (See Qualification for International Players, under chapter on International Badminton, and Eligibility for Ranking under chapter on Ranking.)

13. Player Travel Financing: To the extent that, as determined by the Executive Committee, the finances of the ABA are sufficient to permit the payment of traveling expenses, a U.S. player who competes in the current Closed Championships shall be entitled to be reimbursed for his actual traveling expenses thereto to the extent hereinafter stated, provided such player is:

- a) competing in the current Closed Championships in a singles event and was the winner of such event at the preceding annual Closed Championships (not Senior or Junior) of the ABA (whether such preceding annual Closed Championships were annual championships or otherwise);
- b) competing in the current Closed Championships in a doubles event (other than Senior events) as a member of the same team which competed in such event at such preceding annual Closed Championships and such team was the winner of such event at such preceding annual Closed Championships, (amended October, 1970) unless the International Team Coach requests a change of partners whereupon each member shall receive his or her respective share of the travel allowance that would normally be granted.
- c) planning on playing in both the Closed and Open events of the current Championships.



d) If, as to any event in the current Closed Championships, no player is entitled, according to the above rules, to be reimbursed for traveling expenses, none of the rules shall be deemed to prevent the Executive Committee from reimbursing any top ranked U.S. player or players competing in that event in the current Closed Championships as the Executive Committee may determine upon, for all or part of his or her actual traveling expenses to the extent stated in paragraph e) below.

e) Rules governing reimbursement of travel expenses:

1) The traveling expenses to which players are entitled to reimbursement shall be an amount not exceeding the round trip economy class air fare between the temporary or permanent place of residence of such player and the place where the current Championships are held.

2) Not less than 30 days before the entry deadline of the Championships, the Administrative Secretary of the ABA shall notify each player who is to receive travel expense reimbursement of the approximate amount available to him or her.

3) Player travel rules shall be administered by the ABA Treasurer on approval of the ABA Executive Committee.

14. Financial responsibility of the organization conducting the Championships:

a. Each association, club, or other organization operating a Championships shall pay to the ABA, as an expense of operating such Championships, the sum of \$600.00, or, in lieu thereof, such greater sum as the Executive Committee may designate, which last mentioned sum shall, however, not be in excess of the smaller of the following:

1) the total amount of the players' traveling expenses being reimbursed by the ABA in connection with such Championships, as provided above (a(1)) or

2) \$1,200.00

b. If the Championships are operated by any association or club member of the ABA, any surplus resulting from such operation shall be divided as follows:

1) 50% to the ABA, and

2) if an association, itself, or a club operates the Championships, 50% to such association or club, or

3) if the Championships are operated by a



member club, 25% to such club and 25% to the association sponsoring the same.

c. Television Proceeds: Money obtained as the proceeds of the televising of the Championships of the ABA shall be allocated as follows, subject to the approval of the ABA Executive Committee:

- 1) One third to the ABA General Fund,
- 2) Two thirds to the local tournament committee to be used to promote the stature of the Championships.

d. If the Championships are operated by any other organization, all financial arrangements between such organization and the ABA are to be determined by the Executive Committee.

#### D. Protocol Committee

1. Purpose is to have a special Host Committee for all invited foreign and domestic players and other visitors attending the U.S. Amateur Championships. Committee members should be readily available at all times during the stay of the invited guests while in the Tournament city or site. The Committee should supply the invited players with funds, transportation, housing, and other items that had been agreed upon during the invitation negotiations. The Committee members should be able to answer any and all questions of their guests.
2. Committee personnel:
  - a) The Chairman shall be an ABA Director from the Region in which the Championships is being held and shall be appointed by the ABA President with the approval of the Committee Chairman of the Championships and the associations within said Region.
  - b) Committee members shall be appointed by the Local Championships Committee with the approval of the ABA Protocol Committee Chairman. The number of committee members shall be based on the number and nationality of invited foreign players and visitors.
3. Recommended Guidelines: (See: Invitations to Foreign Players)
  - a) Invitations:
    - 1) Foreign Players - - - Domestic Players: Official invitations shall be sent by the ABA Chairman to the Badminton Association of the countries from which the local Committee wishes to have players attend the Championships, with a copy to the players involved. Such invitations should be extended in the fall preceeding the Championships so that if possible there will be less conflict of dates.



The invitations shall be sent after consultation with the local Championships Committee as to how much money they will be able to spend and which foreign players they would like to have attend their tournament. Invitations to domestic players should be extended to the individual players and those eligible for financial support on transportation costs by the ABA. They will be so notified by the ABA Treasurer in accordance with the rules on U.S. Player travel (C,13).

2) Financial arrangements for Foreign and Domestic players should be made very clear as to how much money will be available for transportation either to and from the United States or to and from their home and the tournament site, as well as at the tournament site of how much money will be given for housing, meals, and other necessities that the Committee feels they can afford.

3). Other Guests and/or Dignitaries (Local politicians, etc.): Invite all guests to all social functions and introduce them publicly as early in the week as possible. Make it clear whether they are to be the guests of the Committee or are to pay their own way to the individual social functions.

4) The ABA strongly recommends that an equal amount of money be spent on U.S. players transportation and living allowances as on foreign players.

b) General Guidelines:

1) Publicity: When foreign players' associations, or the players themselves, have accepted the invitation of the ABA to the Championships, pictures and articles should be obtained from them far enough in advance to make the pictures available for the Official Tournament Program and press releases at the time of the tournament and for advance publicity in local papers.

2) Be certain of the correct spelling and pronunciation of all invited players' and other guests' names.

3) If necessary, and if possible, have interpreters on hand.

4) Provide for special arrangements on religious matters or any national customs that should be observed.

5) Tournament Committee should contact the appropriate USA representatives of the



countries whose players will be entered in the tournament as to the national customs to observe, the securing of flags and national music to be used during the tournament.

6) Make certain that each invited player has transportation at all times once they have arrived in town--particularly between the gym and the hotel or place of lodging when it is time for them to play.

#### IV. SANCTIONS

##### A. Policies

1. All tournaments conducted by association or club members of the ABA should be sanctioned. Sanctions are granted in order to insure adequate control over the tournaments.

2. Sanctions awarded in advance for tournaments to be played after January 1 will be revoked if the association or club is delinquent in the payment of ABA dues at that time. No sanction will be awarded to associations or clubs delinquent in ABA dues for future tournaments, until dues are paid.

3. While the sanctioning system was established in order to avoid conflicts, it does not necessarily follow that the ABA Sanction Committee can refuse to issue a sanction because of a conflict. The Sanction Committee is the clearing house for all tournaments and, while it lists the schedules and makes every effort to avoid conflicts, refusal to sanction is not entirely justified because of two or more tournaments being held on the same date. If, in spite of knowing of the conflicts, the groups desiring to hold the tournaments, wish to go ahead, it is not to the best interests of the game to deny the sanction.

4. No important tournament will be sanctioned in conflict with the National Junior or Amateur Championships.

5. State and regional tournament dates will be given protection within their respective areas.

6. Reasons for sanctioning tournaments other than to avoid conflicts of dates:

- a. To insure that the tournaments will be run according to the ABA regulations.
- b. So that players may be ranked.
- c. To establish official champions in states and regions.
- d. So that all play will be according to the rules and regulations of the ABA and the IBF.
- e. To protect the amateur standing of all players.



f. In order that a record may be kept of the tournament and official recognition given to the winners in the Official Publications of the ABA.

g. To control players' expenses and gate receipts.

7. While it is important for all tournaments to be sanctioned, it is possible for clubs to hold un-sanctioned tournaments. However, these tournaments are not recognized by the ABA and they are not considered for official ranking. Clubs are cautioned to exercise due diligence with respect to all tournament contestants to be certain that there are no violations of the amateur regulations. Players participating in unsanctioned ABA tournaments may be cited for violation of the amateur code in the case professionals participate.

8. Regional tournament sanction chairmen are permitted to recommend sanctioning of a tournament where it is sponsored by an ABA club or association member provided only that amateur players are entered who are residents within the scope of the tournament.

B. Regulations: Tournaments or exhibitions considered as requiring a sanction are those for which the ABA member or the IBF charge an entry fee and/or admission.

1. Tournament Classification: (Approved April, 1970)

a. A tournament will be classified as an "Open" tournament if there is no restriction whatever as to a player's location or affiliation.

b. A tournament will be classified as a "Closed" tournament if there is any restriction whatever as to a player's location or affiliation.

2. Fees: For all tournaments and exhibitions held under the auspices of the ABA, an ABA sanction must be obtained and a fee paid therefor. (Amended 4/71)

a. A fee of \$5.00 will be charged for the sanction if any player, regardless of ability or age may enter the tournament.

b. A fee of \$2.00 will be charged for the sanction of:

1) All tournaments in which an "A" player may not participate;

2) All tournaments in which an "A" player may participate, but only with a player of a lower classification;

3) Tournaments in which only Junior players may participate;

4) Tournaments in which only college students may participate;

5) Tournaments in which only military personnel may participate;



6) Exhibition matches;

7) Tournaments which are basically club matches between clubs within a 25 mile radius.

c. All applications for sanctions must be received by the Chairman of the ABA Tournament Sanction Committee at least one month (30 days) prior to the opening date of the tournament for which the sanction is requested.

3. Penalties for non-filing or late filing for tournament sanction prior to the start of the tournament:

a. For failure to file a sanction request prior to the deadline for filing (30 days prior to the opening date of the tournament), the sanction fee shall be doubled.

b. For failure to file sanction request prior to the start of the tournament, the sanction fee shall be tripled.

c. No future tournament sanction shall be issued until all penalties have been fully satisfied.

3. Sanction Procedure:

a. Plans for the season's tournament play should be developed and sanctions should be requested as early as possible. Plans that affect more than one association in a general area from which tournament entries may be expected should be coordinated directly between all associations having jurisdiction within that area.

b. To avoid serious conflicts of dates, sanction for each tournament shall be procured in accordance with the following:

1) Local tournaments are subject to district or regional sanction;

2) District tournaments are subject to regional association sanction;

3) Regional association tournaments are subject to ABA sanction.

4. Junior tournaments and championships shall be sanctioned in the same manner as adult tournaments and championships and the same ABA policies shall apply.

5. In the event proposed dates clash with any tournament already sanctioned, or if the proposed tournament conditions are considered to be undesirable in the interests of the game by the association responsible for the sanction, the tournament committee concerned shall be advised accordingly and recommendations advanced.



a. Failure to comply with the final decision of the association/s concerned shall oblige the tournament committee concerned to submit the matter to the Chairman of the ABA Sanction Committee for consideration.

b. If the official objection to the tournament is confirmed, the players who competed in the unauthorized tournament shall be suspended from further competition in any tournament.

V. ACTUAL CONDUCT OF THE TOURNAMENT

A. Player Eligibility:

1. No player shall be eligible to compete in any sanctioned tournament:

a. unless he or she is an amateur according to the rules of the ABA or the rules of the national association, other than the ABA, with which the player is affiliated, and

b. except as the Tournament Committee shall otherwise determine in particular cases, unless he or she is either:

1) a member of a club in good standing affiliated with the ABA or with the IBF, or

2) an individual or student member of the ABA.

2. It is the recommendation of the ABA that the age limitations which apply to the National Junior Championships be followed in all other junior tournaments.

3. No ABA member shall knowingly participate in any tournament promoted by an ABA or IBF club or organization unless it has been sanctioned by the ABA or approved by the IBF.

4. Players violating the above regulations shall be ineligible to receive a ranking or to participate in any sanctioned or approved tournament for a period of one year from the date of the violation, subject to review of the Amateur Status Committee.

B. The ABA Match Scheduling (following pages) system of allocating time of play and courts to players should be used in all championships and tournaments.

C. If a challenge cup is not played for in any one season, the player who won it the previous year shall be deemed to have won it that season.

D. Officiating: When an umpire is officiating, the laws of the game shall be enforced by him and in his judgement. In the absence of an umpire, the players concerned shall carry out the rules and if a violation be claimed by one side and not acknowledged by the other, a "let" shall be



be allowed. Umpires are recommended for all semi-final and final matches, and both umpires and linesmen shall be provided for all final matches in any championship tournament. (See current ABA Rules Book.)

E. Tournament Results: Changed April, 1971

1. Results of all ABA sanctioned tournaments shall be sent to the ABA Ranking Chairman on the forms provided by him with each Sanction Approval. In Cup seasons, he will provide the results to the respective coaches.
2. Send complete FINAL results with full names to the Editor of Badminton USA.
3. For tournaments in which Juniors take part, send the results of the junior participation to the Junior Activities Chairman.

F. Tournaments conducted by non-ABA member clubs, schools, or organizations may be sanctioned by the ABA by a direct application to the National Sanction Chairman:

Mr. Cletus Eli  
6303 S. Linden Rd.  
Swartz Creek, MI 48473

G. See the current ABA Rules Book for Referees, Umpires and Linesmen Rules and Regulations.

Note: (Approved April 1971) The ABA interpretation regarding the 1970 IBF service rule pertaining to "undue hesitation" in the delivery of a service be that the service must be delivered within five (5) seconds from the time that both the server and receiver have taken their stances or the server will be faulted.

H. The Draw and Seeding the Draw:

1. The ABA follows the IBF Tournament Regulations for the Draw and Seed of the Open ABA Championships. These regulations are now included in this Handbook.
2. For USA Tournaments other than the Open Amateur Championships the following modifications for the Seed have been approved (February, 1971).
  - a. In case of an entry of 12 or more, but less than 16, there may be two (2) entries placed in addition to the two (2) seeded entries.
  - b. In the case of an entry of 24 or more, but less than 32 entries, there may be two (2) entries placed in addition to the four (4) seeded.
3. A modification for the Closed Championships Draw regulations was approved February, 1971 to allow for the current Junior singles champions to be entered in the ABA Amateur Championships. (See pages 53 and 54)



THE DRAW

1. The draw for all events at Open Tournaments shall be made in the manner set out below, and no dummy entry in singles or dummy pair in doubles may be included in the draw of any championship event. There shall be no alteration in the published draw of any championship event unless permitted under exceptional circumstances by the tournament committee, but no such alteration shall be allowed in singles events, nor in a doubles event if two or more pairs already entered should object.

NOTE.- The purpose of allowing any alteration is to enable a competitor to have a substitute partner in a doubles event if his original partner is prevented from playing through illness, injury, or other unavoidable hindrance. The purpose of allowing alterations is not so that any fresh entries may be introduced.

Immediately any request for alteration is received, competitors in the event concerned shall be acquainted thereof by the Referee by means of a notice prominently displayed on the notice board (if any) and/or in the changing rooms. They shall be given reasonable time to lodge objections which shall be received in confidence.

2. Under no circumstances shall any player be permitted to enter more than once in the same event at any tournament.

3. In no event shall the draw be arranged, except that seeding in championship events shall be permitted under the conditions set out below.

4. The draw shall be conducted as follows:-

When the number of playing units is 4, 8, 16, 32, 64, or any higher power of 2, they shall meet in pairs in the order drawn, as in the following diagram:-

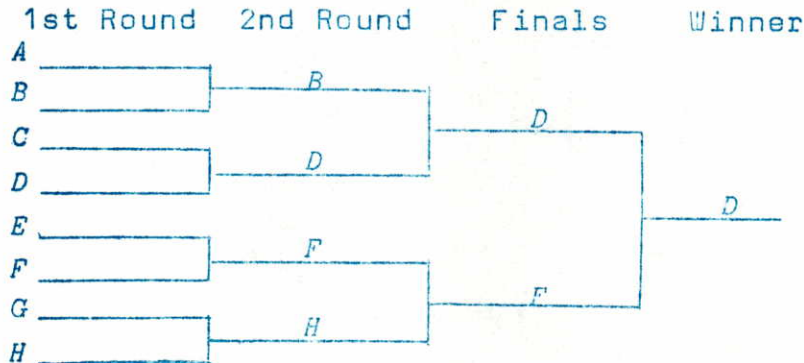

When the number of playing units is not a power of 2, there shall be byes in the first round. The number of byes shall be equal to the difference between the next highest power of 2 and the number of playing units. The



byes, if even in number, shall be divided, as the names are drawn in equal proportions at the top and bottom of the list, above and below the pairs; if uneven in number, there shall be one more bye at the bottom than at the top.

Example - With 19 playing units there will be  $32 - 19 = 13$  byes, 6 at the top and 7 at the bottom of the list, and 3 matches in the first round, 8 in the second, 4 in the third, etc.

Example - with 9 playing units there will be  $16 - 9 = 7$  byes, 3 at the top, and 4 at the bottom, and one match in the first round, see below.

1st Round    2nd Round    3rd Round    Final    Winner

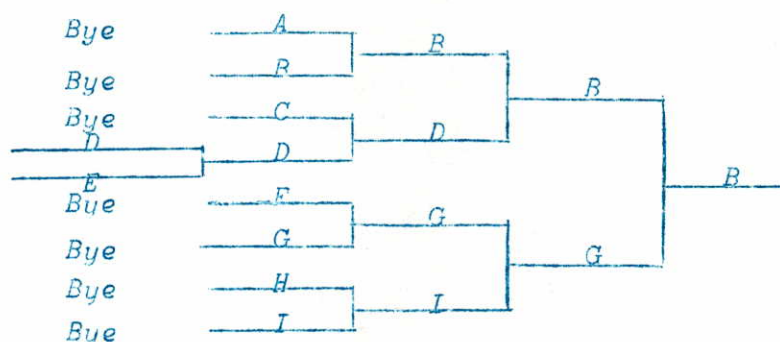

With 5 playing units there will be 1 bye at the top and 2 byes at the bottom.

With 6, 1 bye at the top and 1 bye at the bottom.

With 7, 1 bye at the bottom.

With 8, no byes.

With 9, 3 byes at the top, and 4 byes at the bottom.

With 10, 3 byes at the top and 3 byes at the bottom.

With 11, 2 byes at the top and 3 byes at the bottom.

With 12, 2 byes at the top and 2 at the bottom.

With 13, 1 bye at the top and 2 at the bottom.

With 14, 1 bye at the top and 1 at the bottom.

With 15, 1 bye at the bottom.

With 16, no byes.

And so on with larger numbers in like manner

#### SEEDING THE DRAW

5. At any open tournament, the prospectus of which gives due notice thereof, the draw in the level events may be arranged or "seeded" subject to the following restrictions:-

- (a) Entries to the number of eight, and no more, may be seeded by lot into separate eighths of the draw of an event comprising at least 32 entries; and, similarly, in events comprising fewer entries, four



may be seeded in the case of 16 or more entries, and two in the case of any smaller number, and they shall be drawn by lot into separate quarters, or halves of the draw, as the case may be.

- (b) The entries to be seeded shall be selected by the committee as being, in its opinion, the best in the event.
6. The seeded entries shall be drawn as follows:-
- (a) If two are to be seeded, numbers 1 and 2 shall be drawn by lot; the first drawn shall be placed at the top of the upper half and the second at the bottom of the lower half.
- (b) If four are to be seeded, numbers 1 and 2 shall be placed as above; numbers 3 and 4 shall be drawn by lot and the first drawn shall be placed at the top of the second quarter; the second shall be placed at the bottom of the third quarter.
- (c) If eight are to be seeded, numbers 1, 2, 3 and 4 shall be placed as above; the remainder shall be drawn by lot and placed in the upper half, at the top of the eighths not already occupied and in the lower half, at the bottom of the eighths not already occupied. (See Example below).
7. Any two entries from any country which shall be seeded shall be drawn in separate halves of the draw, and any three or four entries from any one country which shall be seeded shall be drawn in separate quarters of the draw. Note: In the United States, Regions should be considered as countries in this regard.
8. In addition to the seeded entries, in the case of only two entries from any one country, they shall be drawn in separate halves of the draw, and not less than the four best entries from one country, but not more than eight, shall be drawn in separate quarters or eighths, as the case may be. Note: Again treat states or regions in the United States as countries in this matter.

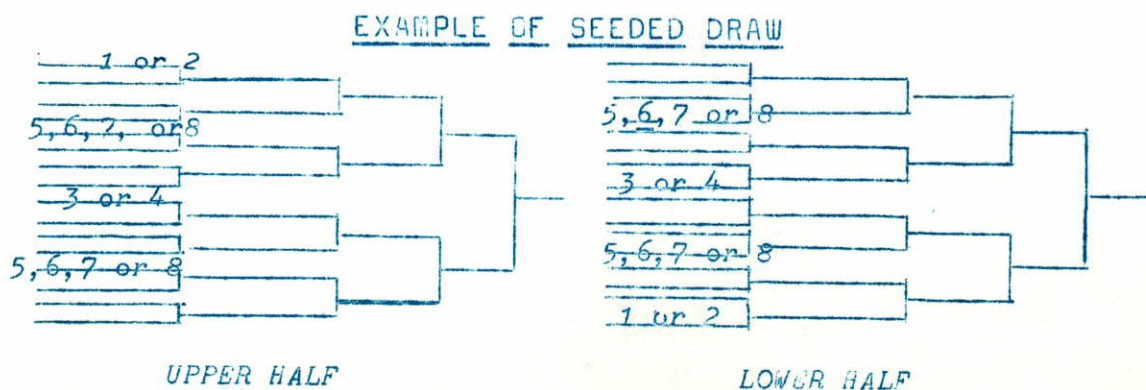



ABA MATCH SCHEDULING

The ABA Match Scheduling system is a process for "programming" a tournament so that each match in each event is scheduled at a definite time on a specific court. Control is exercised through the use of master schedules by the director of play and individual program cards for each player. Each separate match is numbered permitting precise scheduling which is fair to all players.

Allowance of an interval of not less than 1½ hours (if possible) between the starting times of successive matches for any player (or doubles pair), either in the same event or different events, is desirable and possible through proper scheduling.

SYSTEM PROCEDURE AND TOOLS with illustrations:

1. Complete Draw and set up Draw Sheets for all events. (Sample Draw Sheets - Exhibit 1)
2. Determine the number of courts and the time they will be available.
3. Number matches (byes do not count as matches) on the Draw Sheet when tournament is run as a "One Class" tournament: (See Exhibit 2)
  - a. Men's Singles, first round
  - b. Ladies' Singles, first round
  - c. Men's, then Ladies' Singles to quarter-finals
  - d. Men's Doubles to quarter-finals
  - e. Ladies' Doubles to quarter-finals
  - f. Senior events to be fitted in
  - g. Mixed Doubles to quarter-finals

When a tournament includes more than one classification, number matches straight through first round of all events. This will establish the "consolation" draws. Then follow c. - g. above for all events in all classes. Some players entered in more than one class will have to be fitted in. The Control Sheet, if completed through every possibility to the finals will show when such conflicts might arise and adjustments need to be made. (Control Sheet, Exhibit 6)

Exhibit 1  
DRAW SHEETS

*Straight Elimination*

*Consolation Type*

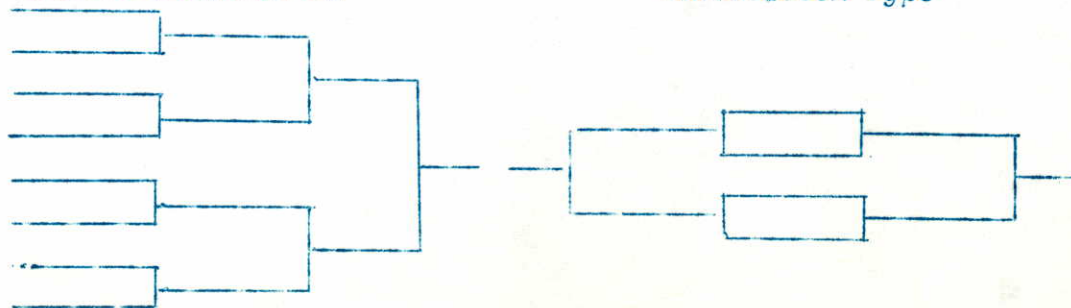



Exhibit 2

NUMBERING MATCHES

Matches Numbered on Draw Sheets - 1 through 232

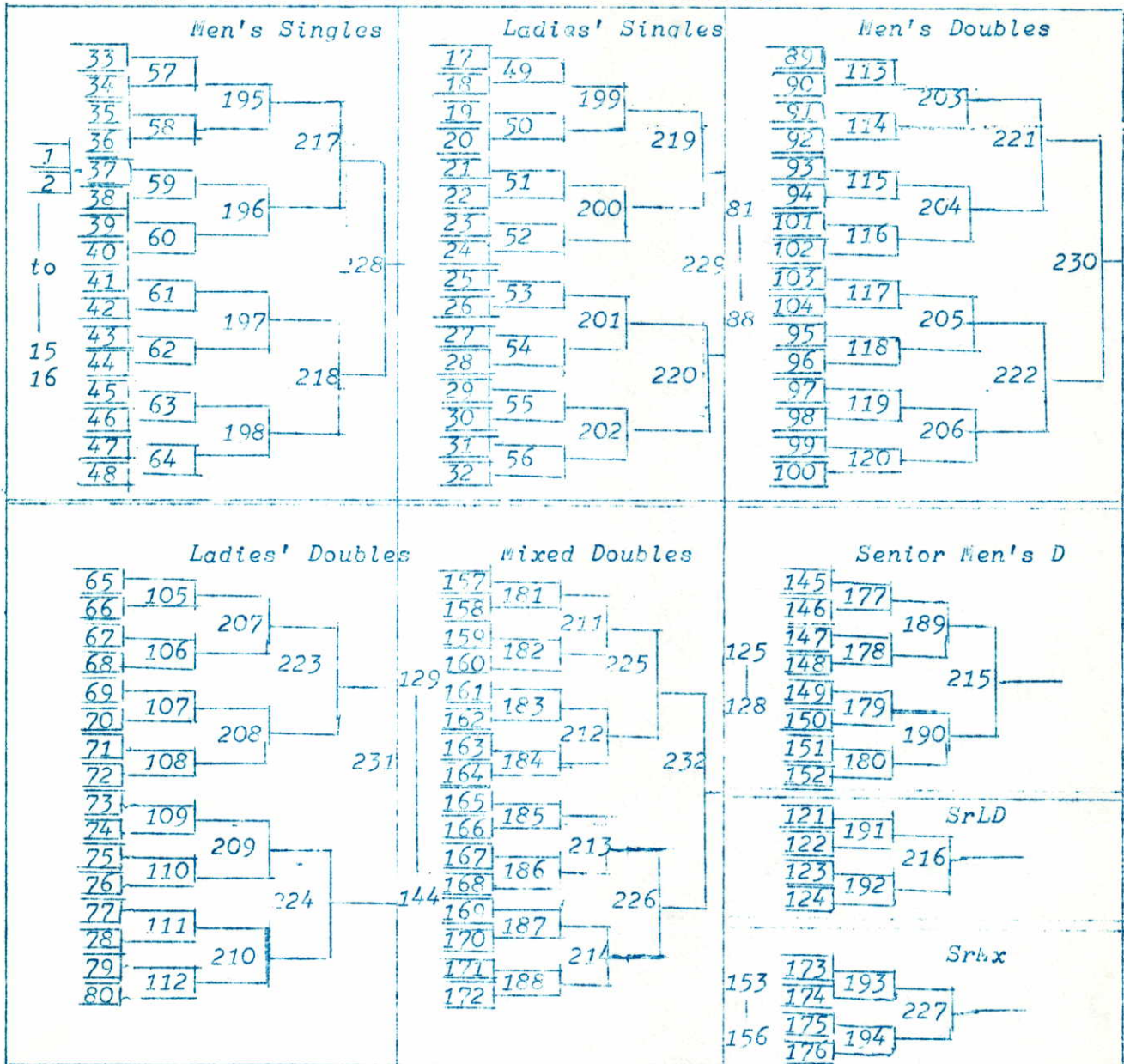

Exhibit 2A

SCORE SHEETS

TWO TYPES

Event          Round          Time          #         

Players                                  us                                 

Winner from #          us         

Winner from #         

Names

1st game                                 

2nd game                                 

3rd game                                 

Results          Posted          Umpire         

Event          Flight          Time          Match#         

   us   

Court          Date         

Names

         123456789101112131415161718

         123456789101112131415161718

         123456789101112131415161718

Results          Posted          Umpire



4. Prepare Schedule Sheets. (See Exhibit 3 for completed sample)
- Allow one vertical column for each court and one horizontal line for each half-hour (for a two day tournament 45 minutes may be better) interval.
  - Number sheets according to the number of matches to be played as indicated on the Draw Sheets. Allow for one unscheduled half-hour or 45 minutes every 7<sup>th</sup> or 8<sup>th</sup> period taking each court in succession.
  - Determine the number of matches to be played prior to the quarter-finals by subtracting 8 from the number of entries in each event.
  - Determine the number of half-hour, or 45 minute periods necessary to have the entire tournament reach the quarter-finals by using the answer to 4.c. above, divided by the number of available courts. This will give an indication of the time the tournament should start so as to finish at a reasonable time.

### Exhibit 3

#### SCHEDULE SHEETS

Symbols used: MS, LS, MD, LD, Mx, SrMD, SrLD, Srx --- Events  
 MS 33 --- Start of Men's Singles event  
 x --- Completion of round for event  
 . --- Open court

First Day					Second Day				
Time	Courts				Time	Courts			
	1	2	3	4		1	2	3	4
AM					AM				
9:00	MS 1	2	3	4	9:00	MD89	90	91	92
9:30	.	5	6	7	9:30	.	93	94	95
10:00	8	9	10	11	10:00	96	97	98	99
10:30	12	.	13	14	10:30	100	.	101	102
11:00	15	16x	LS17	18	11:00	103	104x	LD105	106
11:30	19	20	.	21	11:30	107	108	.	109
12:00	22	23	24	25	12:00	110	111	112x	MD113
PM					PM				
12:30	26	27	28	.	12:30	114	115	116	.
1:00	29	30	31	32x	1:00	117	118	119	120x
1:30	.	MS33	34	35	1:30	.	SrLD121	122	123
2:00	36	37	38	39	2:00	124x	SrMD125	126	127
2:30	40	.	41	42	2:30	128x	.	Mx129	130
3:00	43	44	45	46	3:00	131	132	133	134
3:30	47	48x	.	LS49	3:30	135	136	.	137
4:00	50	51	52	53	4:00	138	139	140	141
4:30	54	55	56x	.	4:30	142	143	144x	.
5:00	MS57	58	59	60	5:00	SrMD	146	147	148
5:30	61	62	63	64x		145			
7:00	LD65	66	67	68	5:30	149	150	151	152
7:30	.	69	70	71	7:00	SrMx	154	155	156x
8:00	72	73	74	75		153			
8:30	76	.	77	78	7:30	.	Mx157	158	159
9:00	79	80x	MD81	82	8:00	160	161	162	163
9:30	83	84	.	85	8:30	164	.	165	166
10:00	86	87	88x	.	9:00	167	168	169	170
					9:30	171	172x	.	SrMX173
					10:00	174	175	176x	



Third Day					Last Day		
Time	Courts				Time	Event	Match
	1	2	3	4	Finals		
9:00AM	SrMD177	178	179	180x	1:15	SrMx	227
9:30	.	Mx181	182	183	2:00	MS	228
10:00	184	.	185	186	2:45	LS	229
10:30	187	188x	.	SrMD180	3:30	MD	230
11:00	190x	SrLD191	192x	.	4:15	LD	231
12:30	SrMx	193	.	194x	5:00	Mx	232
1:15	MS195	196	197	198x			
2:00	LS199	200	201	202x			
2:45	MD203	204	205	206x			
3:30	LD207	208	209	210x			
4:30	Mx211	212	213	214x			
Semi-Finals		Event	Matches				
6:30		SrMD	215	216			
7:15		MS	217	218			
8:00		LS	219	220			
8:45		MD	221	222			
9:30		LD	223	224			
10:30		Mx	225	226			

5. Enter match numbers through quarter-finals on Operations Sheet using symbols to mark start and conclusion of each round of each event on the Schedule Sheet, conclusion of first and second round, match on the court or completed, match winner, and the score. (See Exhibit 4)

Exhibit 4  
OPERATIONS SHEET

TIME	COURT # 1	COURT # 2	COURT # 3	COURT # 4
9:00	on court MS-1 Anderson vs Restel	completed MS-2 Names	Names MS-3	Names MS-4
9:30	OPEN	Names MS-5	Names MS-6	Names MS-7

10:00 --- Continue to make up Operations Sheet according to Schedule Sheets (Exhibit 3)

4:00	Winner 19 LS-50 vs Winner 20	etc. LS-51	etc. LS-52	etc. LS-53
4:30				open

Continue in this way until end of the tournament



6. Set up schedule for the 2 concluding rounds of all events, i.e. semi-finals and finals.
7. Complete Control Sheet (Exhibit 5) with every possibility of winners of each round and each event.
8. Make up Player's Schedule Card from the Control Sheet and mail to players well in advance of tournament dates. (Schedule Card -- Exhibit 6)

Exhibit 5

CONTROL SHEET\*

1st Day Players	Morning						Afternoon			
	9:00	9:30	10:00	10:30	11:00	11:30	12:00	12:30	1:00	etc
Abbott,				MS						
Anderson	MS									
Ash							LS			
Parsons		MS								MS

\* Similar sheets should be made for each day of play or time for remaining matches. Sample does not include all names. Sheets must be filled in with names of all contestants.

Exhibit 6

SCHEDULING CARDS

NAME _____		PARTNERS _____								
Number Events Entered _____		_____								
_____ (Tournament)		_____								
Date _____		Place _____								
	Singles	Doubles		Doubles		Doubles		Doubles		
	Court	Time	Court	Time	Court	Time	Court	Time	Court	Time
Your 1st match is										
If you win you play again at										
Next play										
Players must be at the court and ready to play at the scheduled time. If more than 5 min. late, the match will be defaulted.										

9. Record keeping of the tournament results needs the following 5 items: 1) Draw Sheets; 2) Schedule Sheets; 3) Operation Sheets; 4) Match or Score Sheets (Exhibit 2A); 5) Large Draw Sheets for Bulletin Board so players and spectators may see play progress. Official results from the Score Sheets are entered on the Tournament Manager's Official Draw Sheet and on the Bulletin Board sheets as play progresses.

# # # # #



A P P E N D I X

<u>TABLE OF CONTENTS</u>	<u>PAGE</u>
Constitution, ABA	(1)
Officers, Past and Present ABA	A
Award Recipients:	
United Savings-Helms Hall of Fame	B
Players' Appreciation	B
Kenneth R. Davidson	C
Donors of Perpetual Trophies	D
Junior Champions, ABA	E
National Championships, Location of	F
Champions, National ABA	F
Sample Forms:	
Membership Applications	a.
Tournament Entry Blank	c.



CONSTITUTION  
of the  
AMERICAN BADMINTON ASSOCIATION

Revised 1968  
Amended May 1969

ARTICLE I. NAME

Section 1. This Association, organized July 1936, and incorporated under the laws of the State of Illinois, August 15, 1938, shall be called the AMERICAN BADMINTON ASSOCIATION, hereinafter referred to as the ABA.

Section 2. The ABA is a member association (elected to membership July 19, 1938) of the International Badminton Federation, hereinafter referred to as the IBF.

ARTICLE II. OBJECTIVES

The objectives of the ABA are:

1. To promote and develop the game of badminton in the United States without the purpose of monetary gain; to assist in the development of clubs and associations in the United States; to establish and uphold rules of play and to determine the status of players in the United States, and to arrange and manage national tournaments in the United States; and to sanction regional, sectional, state, city and other local tournaments in the United States.
2. To act as the United States authority in any international tournaments; to choose and manage teams representing the United States in international competition; to represent the United States' interest in international badminton decisions and activities of the IBF.
3. To promote programs developing badminton as a means of healthful recreation, physical and mental fitness, including carryover benefits of badminton as a life-time sport.
4. In order to promote these objectives, to accept, manage and use property of any kind in any manner not prohibited by law to corporations of the type and character of the ABA.

ARTICLE III. MEMBERSHIP

There shall be three (3) classes of members, as follows:

Section 1. ASSOCIATION MEMBERS. Association members shall be those associations now in existence or hereafter formed and which are referred to in Article IV. Section 1 hereof.



Section 2. CLUB/GROUP MEMBERS. Club/Group Members shall consist of:

- (a) any club or organized group (e.g. any private club, YMCA, YWCA, public recreation or other government department, church, educational institution, camp, armed service branch or group, etc.) which is interested in the promotion of badminton in any manner, and in accordance with the rules of the ABA and the IBF, which is a club or group member of the Association Member within the boundaries of which it is located and which has paid the dues prescribed for membership in such association; and
- (b) any such club or group located outside the boundaries of any Association Member which shall have been approved by the Executive Committee of the ABA for Club/Group Membership in the ABA and which shall have paid the dues prescribed for Club/Group Membership in the ABA.

Section 3. INDIVIDUAL MEMBERS. Individual Members shall be divided into the following Four (4) classes:

- (a) CLASS 1 MEMBERS. Individual, 19 years or older, may become a Class 1 Member of the ABA upon application and payment of annual dues prescribed for Class 1 Membership.
- (b) CLASS 2 MEMBERS. Any Individual, under 21 years of age, may become a Class 2 Member of the ABA upon application and payment of annual dues prescribed for Class 2 Membership.
- (c) CLASS 1 LIFE MEMBERS. Any individual, 19 years or older, may become a Class 1 Life Member of the ABA upon application and payment of one lump sum payment prescribed for Class 1 Life Membership, which shall continue during his (or her) lifetime and shall not continue after his (or her) death for the benefit of any member of his (or her) family.
- (d) CLASS 2 LIFE MEMBERS. Any individual, under 19 years of age, may become a Class 2 Life Member of the ABA upon application and payment of one lump sum payment prescribed for Class 2 Life Membership. Upon reaching his (or her) 19<sup>th</sup> birthday, each Class 2 Life Member shall automatically, without additional payment, become a Class 1 Life Member.

#### ARTICLE IV. ASSOCIATIONS

Section 1. The Association Members of the ABA shall be Associations composed of local Club/Groups and/or individuals in areas within one of the respective Regions set forth in Section 2, Article V, provided that:

- (a) There shall not be more than one Association covering the same area (which areas may constitute part or all of any Region);
- (b) such Association shall have been recognized as an affiliate of the ABA either (1) by the provisions of Section 2 of this Article IV, or (2) subsequently by vote of the Board of Directors; and
- (c) the organization, objectives, bylaws and procedures of the Association are deemed by the Board of Directors of the ABA to be in keeping with this Constitution and with the appropriate rules and regulations of the IBF.



Section 2. Recognized Associations as of the date of the adoption of this Constitution in its present form are:

- Region 1. Connecticut Badminton Association  
Massachusetts Badminton Association  
New Hampshire Badminton Association  
Rhode Island Badminton Association
- Region 2. Delaware Valley Badminton Association  
Maryland Badminton Association  
Metropolitan Badminton Association  
Western New York Badminton Association
- Region 3. Southern Badminton Association
- Region 4. Midwest Badminton Association
- Region 5. Southwestern Badminton Association
- Region 6. Northern California Badminton Association  
Oregon Badminton Association  
Southern California Badminton Association  
Washington State Badminton Association

Section 3. Local clubs, groups and/or individuals forming an additional or revised Association may be recognized by the Board of Directors, consistent with the provisions of Section 1 of this Article IV, as additional or revised Associations following the filing of a petition for such recognition with the Membership Committee as contemplated by Paragraph 4 of Section 3 of Article VIII hereof.

#### ARTICLE V. BOARD OF DIRECTORS

Section 1. The active management of the ABA shall be vested in a Board of Directors.

Section 2. Effective 1 July 1969, the Board shall consist of the President, the Vice-Presidents, the Immediate Past President, the Secretary-Treasurer (or the Secretary and the Treasurer, as the case may be) and thirty (30) Directors representing the following six (6) Regions of the United States:

- Region 1. (New England): Connecticut, Maine, Massachusetts, New Hampshire, Rhode Island, Vermont;
- Region 2. (Middle Atlantic); Delaware, District of Columbia, Maryland, New Jersey, New York, Pennsylvania, West Virginia;
- Region 3. (Southern): Alabama, Arkansas, Florida, Georgia, Louisiana, Mississippi, North Carolina, South Carolina, Tennessee, Virginia;
- Region 4. (Midwestern): Illinois, Indiana, Iowa, Kentucky, Michigan, Minnesota, Missouri, Ohio, Wisconsin;
- Region 5. (Western): Colorado, Kansas, Montana, Nebraska, New Mexico, North Dakota, Oklahoma, South Dakota, Texas, Utah, Wyoming;
- Region 6. (Pacific): Alaska, Arizona, California, Hawaii, Idaho, Nevada, Oregon, Washington.



Section 3. Each Director shall be elected by the Association, Club/Group, Class 1, Class 1 Life, Class 2, and Class 2 Life Members within or affiliated with the Region which he (or she) represents. Each Director must be a Class 1 or Class 1 Life Member residing within the Region which he (or she) represents.

Section 4. Subject to the immediately following sentence, each Director shall be elected for a two-year term and shall continue to serve out the term, provided he (or she) continues to be a Class 1 or Class 1 Life Member residing within the Region which he (or she) represents. Terms of office shall be set such that in the case of each Region the number of Directors elected in each year shall be one-half of the total number of Directors to which such Region is entitled, if this total is evenly divisible by two, or if not, one-half of such total number as increased by one.

Section 5. Each year, the Executive Committee shall apportion the Directorships to be filled among the six (6) Regions. Each Region shall be entitled to that proportion of the thirty (30) Directors as the aggregate number of votes represented by the ABA Membership in such Region of all classes bears to the aggregate number of votes represented by the entire ABA Membership of all classes (all as ascertained by the Secretary or Secretary-Treasurer, as the case may be); provided, always, that each Region must have at least two (2) Directors. Fractional adjustments required in connection with Directorships shall be determined by the Executive Committee. Apportionment of Directorships to be filled each 1 July shall be based on the aforesaid membership as of the end of the prior fiscal year.

Section 6. If the office of any elected Director becomes vacant by reason of death, resignation, election to the office of President or Vice-President, or appointment to the office of Secretary-Treasurer (or Secretary or Treasurer), the President may appoint such successor as he shall determine upon, for a term ending at midnight on 1 June following the next Annual General Meeting, which appointment shall be subject to the qualification requirements of Section 3 of this Article V and to ratification of the appointment by an affirmative vote of two-thirds (2/3) of the members of the Board of Directors. Without hereby limiting the foregoing power of the President of the ABA to make such appointment as he shall determine upon, it shall be his duty to inquire of the President of each Association Member within the Region as to which the Directorship vacancy exists whom he suggests as Director to fill the vacancy.

Section 7. Each Director shall have the right to designate a proxy from his (or her) own Region to attend any regular or special meeting of the Board of Directors and to vote thereat in his (or her) place. Any such proxy must be a Class 1 or Class 1 Life Member within such Region and shall have the full right to participate in a regularly called meeting of the Board of Directors, including the right to vote; provided, however, that no person shall be entitled to hold more than one proxy at any meeting.



Section 8. Irrespective of requirements specified in Sections 2,3,4,5, and 6 of this Article V, any Director who was elected prior to 1 July 1968 shall finish out the term for which he (or she) was originally elected, except that to continue in office after September 1968. he (or she) must become and maintain a Class 1 Life or Class 1 Membership.

Section 9. The Executive Committee, by 20 January 1969, shall determine the number of Directorships to be filled to raise the total number to thirty (30) as of 1 July 1969 and apportion them in accordance with Section 5 of this Article V. taking into account the regional affiliations of all Directors holding over to 30 June 1970.

#### ARTICLE VI. OFFICERS

Section 1. The officers of the ABA shall consist of a President, a First Vice-President, a Second Vice-President, and, as the President shall determine as to any fiscal year, either (a) a Secretary-Treasurer, or (b) a Secretary and a Treasurer.

Section 2. The term of office of the President shall be two years, and of each Vice-President one year. Each of said terms of office shall coincide with the fiscal years or year until such time as the officer is succeeded in his (or her) office by an officer duly elected under provisions of Section 6 and 7 of Article X. The President shall be elected biannually in each even year by majority vote of the Board of Directors. The Vice-Presidents shall be elected annually by a majority vote of the Board of Directors. To be eligible for election as President, or as a Vice-President, the individual must be a Class 1 or Class 1 Life Member. In addition, to be eligible for election as President, the individual must have served at least two years as a Vice-President and/or Director. Not more than one such officer shall be a Member residing within Region 1 and 2, nor more than one shall be a Member residing within Regions 3 and 4, nor more than one shall be a Member residing within Regions 5 and 6.

Section 3. The Secretary-Treasurer (or the Secretary and Treasurer, as the case may be) shall be appointed by the President with the approval of the Board of Directors. The term of office shall coincide with the fiscal year.

Section 4. The President shall be the chief executive officer of the ABA and shall preside at all meetings of the ABA and all meetings of the Board of Directors. He (or she) shall be, by virtue of his (or her) office, a member of all committees of the ABA except, if one be appointed, the Auditing Committee.

Section 5. The Secretary-Treasurer (or the Secretary and Treasurer each, as the case may be) shall be directly responsible to the Directors for the usual duties incident to their respective offices.

#### ARTICLE VII. DUES AND VOTING

Section 1. Each Association Member, each individual Member and each Club/Group Member referred to in Article III, Section 2, paragraph (b) shall pay annual dues to the ABA in an amount to



be determined annually by the Executive Committee of the ABA subject to approval of the Board of Directors, provided that, each Life Member shall make one lump sum payment to the ABA in an amount to be determined from time to time by the Executive Committee, subject to approval of the Board of Directors.

Section 2.

(a) Each ABA Association Member shall be entitled to a total number of votes equal to the sum of the following votes (relating to the Club/Group Members belonging to such association and referred to in Article III, Section 2(a), of this constitution):

(1) In the case of each such Club/Group Member referred to in said Section 2(a) which, as determined by the ABA Executive Committee, is a badminton club or group, or the membership of which is made up in part, expressly or otherwise, of a badminton membership,-- one vote for each individual who (as of such date as shall have been designated by the ABA Executive Committee, subject to the approval of the ABA Board of Directors) was a badminton member of such Club/Group Member; plus

(2) In the case of each such Club/Group Member referred to in the aforesaid Section 2(a) which is not included within item (1) above because, as determined by the ABA Executive Committee, it is not a badminton club or group and its membership is not made up in part, expressly or otherwise, of a badminton membership,--such number of votes, if any, as shall have been designated for such last-mentioned other Club/Group Members by the ABA Executive Committee, subject to the approval of the ABA Board of Directors.

(b) Each Club/Group Member (referred to in Article III, Section 2(b), of this constitution) not belonging to any ABA Association Member shall respectively be entitled to the following number of votes, namely:

(1) In the case of each such Club/Group Member referred to in said Section 2(b) which, as determined by the ABA Executive Committee, is a badminton club or group, or the membership of which is made up in part, expressly or otherwise, of a badminton membership,--one vote for each individual who (as of such date as shall be designated by the ABA Executive Committee, subject to the approval of the ABA Board of Directors) was a badminton member of such Club/Group Member.

(2) In the case of each such Club/Group Member referred to in the aforesaid Section 2(b) which, as determined by the ABA Executive Committee, is not included within item (1) above because it is not a badminton club or group and its membership is not made up in part, expressly or otherwise, of a badminton membership,--such number of votes, if any, as shall have been designated for such last-mentioned other Club/Group Members by the ABA Executive Committee, subject to the approval of the ABA Board of Directors.

(c)1 Ballots required in connection with Association (defined in Section 2(a) of this Article VII) voting shall be mailed by



the ABA Secretary to the association presidents. The association shall conduct the balloting and report the results to the ABA Secretary.

2 Ballots for use by Club/Group Members referred to in paragraph b above shall be mailed by the ABA Secretary to such Club/Group Member, which Club/Group Member shall conduct the balloting and report the result to the ABA Secretary.

3 Each individual Member shall be entitled to one vote. Ballots for individual Members shall be mailed by the ABA Secretary to each such Member, who shall cast the ballot with the ABA Secretary.

Section 3. The Membership year of the ABA shall be its fiscal year as hereinafter fixed by Section 1 of Article XI. All Memberships except Life Memberships shall expire each 30 June. Membership becomes effective upon receipt of dues (a) by the Secretary of the ABA, or (b) by such other person or persons as shall have been authorized to receive the same by said Secretary or by the President of the ABA.

Section 4. Notwithstanding anything contained elsewhere in this Constitution, if, at any time when membership in the ABA is to be determined, any association which shall have been recognized as an affiliate of the ABA, - or any club or group (referred to in Article III, Section 2(b), of this Constitution) not belonging to any ABA Association Member, - shall have paid less than the full amount of its dues for the then current fiscal year, such association, or club or group shall nevertheless be deemed for all of the purposes of this Constitution to be an Association Member, or Club/Group Member, of the ABA in such fiscal year, but (instead of being entitled to vote as provided in Section 2(a), or Section 2(b), of this Article) such Association Member, or Club/Group Member, shall be entitled to vote only such part of the full number of votes, as so provided, as is proportionate to the portion of its dues paid for such fiscal year.

#### ARTICLE VIII. COMMITTEES

Section 1. The President, the Vice-Presidents, the Immediate Past President, and the Secretary-Treasurer (or the Secretary and the Treasurer, as the case may be) shall constitute the Executive Committee for the administration of the affairs of the ABA. The Editor of the official publication of the ABA shall be a non-voting, ex-officio member of the Executive Committee.

Section 2. In addition to special committee Chairmen who may be appointed from time to time, the President shall appoint the Chairmen of the standing Committees referred to in Section 3 of this Article VIII, with the advice and consent of the Board of Directors, and may appoint the members of each such Committee (with the advice and consent of the Board of Directors) if he elects to do so, provided, always, that if and to the extent that the President does not so elect, the members of any such Committee shall be appointed by the Chairman of the Committee, with the advice and consent of the Board of Directors.

Section 3. Standing Committees and the respective duties of each are:



- (1) Rules Committee. It shall be the duty of this Committee to uphold the rules of play as established by the IBF; to be the arbiter on all points of dispute, and to be responsible, if and when required for the establishment and operation of an Umpires' Association.
- (2) Amateur Status Committee. It shall be the duty of this Committee to determine whether or not individuals entered in sanctioned tournaments are amateurs. The Committee shall develop, and from time to time perfect, a code for the guidance of its sub-committee for the interpretation of the rules for amateur standing. The Committee shall have the authority to make such rulings on both the eligibility and reinstatement of individuals as may be necessary and proper in the administration of the rules of amateur standing.
- (3) Ranking and Tournament Sanction Committee. It shall be the duty of this Committee to determine the national ranking of players and report their findings to the Secretary annually ninety (90) days after completion of the National Championships (Senior). It shall also have authority to sanction all ABA recognized regional, sectional, state and local tournaments and exhibitions.
- (4) Membership Committee. It shall be the duty of this Committee to:
  - (a) promote and assist the orderly establishment of Associations;
  - (b) recommend to the Board of Directors the affiliation of new or changed Associations; and
  - (c) recommend organizational and/or financial assistance that should be given to any Association.
- (5) Championships Committee. It shall be the duty of this Committee to manage and supervise the Annual National Championships, working in co-operation with such local committees as may be appointed.
- (6) Badminton News Committee. It shall be the duty of this Committee to promote publicity pertaining to the development of the game, co-operating at all times with the staff of the official publications of the ABA.
- (7) Shuttlecock Committee. It shall be the duty of this Committee to test shuttlecocks and determine their eligibility for tournament play and to select the one used in each National Championships.
- (8) Thomas Cup Committee. It shall be the duty of this Committee:
  - (a) to manage all operations pertaining to training and selection of players for the international competition for the Thomas Cup;
  - (b) to be responsible to the Board of Directors for the operation of any Thomas Cup ties held in this country, or for the details of arrangements of such ties if held in other countries, as they pertain to the United States team;
  - (c) to develop and operate a program for the furtherance of Thomas Cup teams, under the approval of the Board of



Directors or the Executive Committee of the ABA. The Chairman of the Ranking and Tournament Sanction Committee shall automatically be a member of this Committee.

- (9) Uber Cup Committee. It shall be the duty of this Committee:
- (a) to manage all operations pertaining to the training and selection of players for the International badminton competition for the Uber Cup;
  - (b) to be responsible to the Board of Directors for the operation of any Uber Cup ties held in this country, or for the details of arrangements of such ties, if held in other countries, as they pertain to the United States teams; and
  - (c) to develop and operate a program for the furtherance of Uber Cup teams, under the approval of the Board of Directors or Executive Committee of the ABA. The Chairman of the Ranking and Tournament Sanction Committee shall automatically be a member of this Committee.

- (10) Junior Activities Committee. It shall be the duty of this Committee to promote and develop junior play, establish national rankings of juniors and co-operate with the Championships Committee in conducting the National Junior Championships.

- (11) Nominating Committee. So far as feasible, this Committee shall consist of one member from each of the ABA Regions. It shall be the duty of this Committee to nominate Directors as necessary for election each year. Its report shall be submitted in writing to the Secretary fifty (50) days prior to the Annual General Meeting of the ABA and such report shall be sent to every Member as defined in Article III hereof thirty (30) days before the Annual General Meeting.

Without hereby limiting the foregoing power of the Nominating Committee to make such nominations as it shall determine upon, it shall be the duty of this Committee to inquire of the President of each Association Member within each Region with respect to which a Director is to be elected whom he suggests as such Director. It shall likewise be the duty of this Committee, if requested to do so by the Executive Committee, to submit to such Executive Committee, for transmittal to members of the Board of Directors, a list of suggested nominees for offices to be filled by election by the Board of Directors as provided in Section 7 of Article X.

Section 4. All Committees listed in Section 3 of this Article VIII shall serve for the fiscal year of the ABA and until their successors are appointed. Each Committee Chairman shall make an annual report to the President prior to 1 July each year.

Section 5. Any Member (including any member of any member clubs or groups) shall have the right to appeal the decision of a Committee to the Executive Committee or to the Board of Directors.



Section 6. Committee Rules and Regulations shall be published in the ABA HANDBOOK, reviewed from time to time by the Committee Chairmen and the Board of Directors, and may be changed by vote of the Board of Directors.

ARTICLE IX. OFFICIAL PUBLICATIONS  
OR PUBLICATION

There shall be at least one official publication of the ABA which, as issued, shall be sent to each of the following Members (all as defined in Article III): (1) Association, (2) Club/Group, (3) Individual. The Editor of each official publication of the ABA shall be appointed by the President, subject to the approval of the Executive Committee, and each shall serve until his (or her) successor is appointed. Such one of said Editors as shall be designated by the Executive Committee shall be an ex-officio member of the Executive Committee with no voting privilege.

ARTICLE X. MEETINGS

Section 1. An Annual General Meeting shall be held in conjunction with the National Championships (Senior) at such time and place as is determined by the Board of Directors, at least thirty (30) days' notice thereof to be given by mail to the voting Membership by the Secretary-Treasurer (or Secretary, as the case may be).

Section 2. The Annual Meeting of the Directors shall be held in conjunction with the National Championships (Senior) in such manner and place as is determined by the President. At least thirty (30) days' notice of such meeting, and of any other meeting of the Directors to be held in person, shall be given by mail to each member of the Board of Directors by the Secretary-Treasurer (or Secretary, as the case may be).

Section 3. Other meetings of the Directors shall be held in September, November, January and June, and may be held either in person or by mail as may be arranged by the President.

Section 4. Special meetings of the Directors may be called by the President at any time and must be called by him upon request of five (5) Directors.

Section 5. Quorum. A quorum for the conduct of business at the Annual General Meeting shall consist of those present in person or by proxy representing 5% of the total number of votes entitled to be voted at the meeting. Except in the case of an amendment to this Constitution, a balloting by mail shall be determined by a majority of the votes or applicable ballots received within such time as is designated therefor on the ballot, whatever percent of the total voting Membership shall have voted. A vote for an amendment of this Constitution shall be deemed to have been duly adopted if two-thirds of the votes received within forty (40) days after the Annual General Meeting to which the amendment has been submitted are in favor thereof. A quorum for the conduct of business at a meeting of the Board of Directors shall be twelve (12), of which eight (8) must be present in person.



Section 6. Nominations. At the Annual General Meeting, the Chairman of the Nominating Committee shall present the Committee's nominations for Directors, following which nominations from the floor shall be in order until declared closed by the President.

(a) Each floor nomination for Director shall be in writing, giving the name of the nominee, his (or her) signature indicating acceptance, the Region he (or she) represents, and signatures of at least five (5) Members residing within such Region who endorse the nomination.

(b) To be eligible for nomination as a Director, an individual must meet the qualifications of Section 3, Article V. The Secretary-Treasurer (or the Secretary, as the case may be) shall certify that each nominee fulfills the eligibility requirements appropriate in each case and that each endorser is a Member residing within the appropriate Region.

Section 7. Ballots for election of Directors shall be mailed to each voting Member, as defined in Article VII, Section 2, before 1 May of each year, to be returned to the Secretary-Treasurer (or the Secretary, as the case may be). The election shall close midnight 1 June. The Board of Directors for the ensuing fiscal year (newly elected and non-retiring Directors) shall then elect the officers (President biannually, Vice-Presidents annually) by mail ballot sent to each Director before 5 June. The election of officers shall close midnight 30 June. If as to any one of the officers, no candidate obtains a majority of votes received by midnight 30 June, a run-off ballot shall be mailed immediately listing the two candidates receiving the largest and the next largest number of votes. The run-off election shall close midnight 30 July.

#### ARTICLE XI. MISCELLANEOUS

Section 1. The fiscal year shall begin 1 July of the year.

Section 2. Membership in the ABA, as defined in Article III, becomes effective 1 July 1968.

#### ARTICLE XII. AMENDMENTS

Section 1. Any proposed amendment to this Constitution must be endorsed by at least five (5) Individual Members or the Executive Committee, or by any Association Member and shall be submitted in writing to the Secretary-Treasurer (or the Secretary as the case may be) at least fifty (50) days prior to the Annual General Meeting, copies shall be mailed to each voting Member, as defined in Article VII, Section 2, at least thirty (30) days before such meeting.

Section 2. Votes on amendments to this Constitution shall be adopted only by mail vote pursuant to Section 5 of Article X hereof.



OFFICERS OF  
THE AMERICAN BADMINTON ASSOCIATION

	<u>1936-1937</u>	<u>1937-1938</u>
President:	Donald E. Wilbur, Boston	Donald E. Wilbur
1st V.P.	Wm. H. Ferguson, Seattle	Leslie I. Nichols, Calif.
2nd V.P.	W. H. Walter, Chicago	W. Hamilton Walter
Sec.-Treas.	Robert L. McMillan, Boston	Robert L. McMillan
	<u>1938-1939</u>	<u>1939-1940</u>
President:	W.H. Walter, Chicago	W. Hamilton Walter
1st V.P.	W.W.Frazier, 3rd, Phila.	W.W.Frazier, 3rd
2nd V.P.	Orville H. Mills, Seattle	Orville H. Mills
Sec.-Treas.	Norval P. Trimborn, Chicago	Norval P. Trimborn
	<u>1940-1941</u>	<u>1941-1942</u>
President:	Orville H. Mills, Seattle	R. Ward Starrett, Chicago
1st V.P.	R. Ward Starrett, Chicago	W.W. Frazier, 3rd, Phila.
2nd V.P.	W.W. Frazier, 3rd, Phila.	W. Kelso, San Antonio
Sec.-Treas.	T.E. Ough, Seattle	J.H. Canfield, Chicago
	<u>1942-1943</u>	<u>1943-1946</u>
President:	R. Ward Starrett, Chicago	J.F. Crafts, Boston
1st V.P.	A.N. Smith 2nd, Charlotte	A.N. Smith, Charlotte
2nd V.P.	James F. Crafts, Boston	-----
Sec.-Treas.	Justin H. Canfield, Chicago	John E. Garrod, Boston
	<u>1946-1947</u>	<u>1947-1948</u>
President:	Warren Wheary, Chicago	Warren Wheary
1st V.P.	L. Gustavson, Westport	R.G. Scarlett, Baltimore
2nd V.P.	T.M. Royce, Seattle	T.M. Royce
Sec.-Treas.	F.W. Russell, Chicago	Rufus D. Beach, Chicago
	<u>1948-1949</u>	<u>1949-1950</u>
President:	T.M. Royce, Seattle	T.M. Royce
1st V.P.	D. Richardson, Boston	D. Richardson
2nd V.P.	W.H. Vaughan, Atlanta	W.H. Vaughan
Sec.-Treas.	H.B. Law, Seattle	H.B. Law & R.O. Yeager
	<u>1950-1951</u>	<u>1951-1952</u>
President:	D. Richardson, Boston	D. Richardson
1st V.P.	R.W. Jordan, St. Louis	Roy W. Jordan
2nd V.P.	H.P. Smith, Arcadia	Hulet P. Smith
Sec.-Treas.	P. Richardson, Boston	P. Richardson
	<u>1952-1953</u>	<u>1953-1954</u>
President:	R.W. Jordan, St. Louis	R. W. Jordan
1st V.P.	H.P. Smith, Arcadia	C. B. Newhall, Boston
2nd V.P.	C. B. Newhall, Boston	C.W. Welcome, Glendale
Sec.-Treas.	H.H. Perkins, Jr., Rockhill	H.H. Perkins, Jr.



## OFFICERS OF THE AMERICAN BADMINTON ASSOCIATION - 2

	<u>1954-1955</u>	<u>1955-1956</u>
President:	C. B. Newhall, Boston	C. B. Newhall
1st V.P.	C. W. Welcome, Glendale	C. W. Welcome
2nd V.P.	R. A. Baird, Chicago	R. A. Baird
Secretary	R. G. Slauer, Marblehead	R. G. Slauer
Treasurer	Helen Gibson, E. Norwalk	Helen Gibson
	<u>1956-1957</u>	<u>1957-1958</u>
President:	C. W. Welcome, Glendale	C. W. Welcome
1st V.P.	R. A. Baird, Neenah, WI	R. A. Baird
2nd V.P.	E. S. Jarrett, New York	E. S. Jarrett
Secretary	J. H. vanPraag, Pasadena	J. H. vanPraag
Treasurer	M.J. Armendariz, Glendale	M.J. Armendariz
	<u>1958-1959</u>	<u>1959-1960</u>
President:	E.S. Jarrett, New York	E.S. Jarrett
1st V.P.	Carl Andersen, Seattle	Carl Andersen
2nd V.P.	P. Hinkle, Jr., Ohio	P. Hinkle, Jr.
Secretary	K. F. MacDonald, New York	K. F. MacDonald
Treasurer	M.J. Armendariz, Glendale	M. J. Armendariz
	<u>1960-1962</u>	<u>1962-1964</u>
President:	C. Andersen, Seattle	P. Hinkle, Jr., Ohio
1st V.P.	P. Hinkle, Jr., Ohio	A.O. Laubinger, Mass.
2nd V.P.	Helen Gibson, E. Norwalk	W. K. Lyon, San Diego
Secretary	Gladys Mallory, Seattle	R. Gammons, Ohio
Treasurer	Virginia Hill, Glendale	Virginia H. Mosdale
	<u>1964-1966</u>	<u>1966-1968</u>
President:	A.O. Laubinger, Mass.	W.K. Lyon, San Diego
1st V.P.	W. K. Lyon, San Diego	T. Caffery, New Orleans
2nd V.P.	T. Caffery, New Orleans	Z. Obara, Ohio (1966)
		W. Schell, Mass. (1967)
Secretary	Wm. von Rosenvinge, Mass.	Virginia B. Lyon, San Diego
Treasurer	Virginia H. Mosdale, CA	Virginia H. Mosdale (died 1967)
	<u>1968-1970</u>	
President:	T. Caffery, New Orleans	
1st V.P.	Wm. Goodman, Mass.	
2nd V.P.	Helen Tibbetts, Los Angeles	
Secretary	Betty Brown, New Orleans	
Treasurer	Virginia Lyon, San Diego	
	<u>1970-1972</u>	<u>1971-1972</u>
President:	Wm. Goodman, Mass.	Wm. Goodman, Mass.
1st V.P.	Helen Tibbetts, Calif.	Cletus Eli, Mich.
2nd V.P.	Cletus Eli, Mich.	Howard Schwitkis, Calif.
Secretary	Wm. von Rosenvinge, Mass.	Wm. von Rosenvinge, Mass.
Treasurer	Virginia Lyon, Calif.	Virginia Lyon, Calif.



UNITED SAVINGS  
 HELMS BADMINTON HALL OF FAME  
 AWARD RECIPIENTS  
 \* \* \* \* \*

- 1956 -- Joseph C. Alston, So. Pasadena, California  
 David G. Freeman, San Diego, California  
 Walter Kramer, Detroit, Michigan  
 Ethel Marshall, Buffalo, New York  
 Wynn Rogers, Arcadia, California  
 Mrs. Del Barkhuff (Now Mrs Bertha Cunningham) Santa  
 Barbara, California  
 Mrs. Thelma Welcome, Pasadena, California
- 1957 -- Hamilton B. Law, Seattle, Washington  
 Richard O. Yeager, Seattle, Washington
- 1958 -- Evelyn Boldrick Howard, San Diego, California  
 Zoe Smith Yeager, Seattle, Washington
- 1959 -- Helen Gibson, East Norwalk, Connecticut
- 1960 -- Janet Wright, San Francisco, California
- 1961 -- T. M. Royce, Seattle, Washington
- 1962 -- Donald Richardson, Waban, Massachusetts
- 1963 -- Mrs. G.C.K. Hashman, England
- 1964 -- No Award
- 1965 -- Margaret Varner (Now Mrs. Wm. G. Bloss, El Paso, Texas  
 Chester Goss, San Diego, California
- 1966 -- Mrs. Hulet P. Smith, Pebble Beach, California
- 1967 -- Marten Mendez, San Diego, California
- 1968 -- Mrs. Joseph C. Alston, So. Pasadena, California
- 1969 -- Beatrice Massman, Buffalo, New York
- 1970 -- James Poole, New Orleans, Louisiana
- 1971 -- Mrs. Helen Tibbetts, Los Angeles, California

- - - - -  
 PLAYER APPRECIATION AWARD

- 1966 -- Jack van Praag, Pasadena, California
- 1967 -- Mrs. Virginia Hill Mosdale, Glendale, California
- 1968 -- Tim Royce, Seattle, Washington
- 1969 -- Charles Newhall, Boston, Massachusetts
- 1970 -- None    1971 -- None



KENNETH R. DAVIDSON

MEMORIAL AWARD FOR SPORTSMANSHIP

\* \* \* \* \*

Adult Award

- 1955 - Janet Wright  
San Francisco, Calif.
- 1956 - Helen Gibson  
E. Norwalk, Conn.
- 1957 - Eddy Choong  
Penang, Malaya
- 1958 - Susan Devlin Peard  
Owings Mills, Maryland
- 1959 - Joseph Alston  
Pasadena, California
- 1960 - Wayne Schell  
Boston, Massachusetts
- 1961 - Helen Tibbetts  
Gardena, California
- 1962 - Ethel Marshall  
Buffalo, New York
- 1963 - Lois Alston  
Pasadena, California
- 1964 - Dick Mitchell  
San Diego, California
- 1965 - Taylor Caffery  
New Orleans, Louisiana
- 1966 - Mrs. G.C.K. Hashman  
England
- 1967 - Beatrice Massman  
Buffalo, New York
- 1968 - Waldo K. Lyon  
San Diego, California
- 1969 - Wynn Rogers  
Arcadia, California
- 1970 - Ted Moehlmann, Jr.  
St. Louis, Missouri
- 1971 - Dr. Charles Thomas  
Natchitoches, Louisiana

Junior Award

- 1955 - Robert Steinwald  
Baltimore, Maryland
- 1956 - Marcia Dotson  
St. Paul, Minnesota
- 1957 - Bernard Talley, Jr.  
Baltimore, Maryland
- 1958 - Stanton Hales  
Pasadena, California
- 1959 - MariBeth Halloran  
Minneapolis, Minnesota
- 1960 - James Lynch  
Snyder, New York
- 1961 - Barbara Bump  
Greenwich, Conn.
- 1962 - Susan Vening  
Manhattan Beach, Calif.
- 1963 - Lani Ferris  
Baltimore, Maryland
- 1964 - Sharon Pritula  
Detroit, Michigan
- 1965 - Larry Saben  
San Gabriel, California
- 1966 - Cindy Root  
Philadelphia, Penn.
- 1967 - Susan Wilson  
Port Angeles, Wash.
- 1968 - Nancy Bender  
Wilmington, Delaware
- 1969 - Chris Burton  
Port Angeles, Wash.
- 1970 - Ken Nelson  
Tacoma, Washington
- 1971 - Douglas Lender  
Wilmington, Delaware



## DONORS OF PERPETUAL CHALLENGE TROPHIES

## AMERICAN BADMINTON ASSOCIATION

## AMATEUR CHAMPIONSHIPS

- MEN'S SINGLES: The Bayard Clarke, E. Langdon Wilkes & Howland Pell Memorial Challenge Trophy, presented by Walter Rysam Jones.
- LADIES' SINGLES: Miss Alouise Boker, New York City.
- MEN'S DOUBLES: Leander McCormick-Goodhart, Alexandria, Virginia.
- LADIES' DOUBLES: Mrs. F. Richards Ford, Jr., New York City.
- MIXED DOUBLES: H.H.Hunter Memorial Challenge Cup, presented by the Geneva Badminton Club, Ill.
- SENIOR MEN'S DOUBLES: Dodge Memorial Bowl, presented by the Wissehickon Badminton Club, Philadelphia.
- SENIOR LADIES' DOUBLES: Bergman-Gibson Challenge Trophy, presented by Helen Gibson & Mrs. Roy A. Bergman.
- SENIOR MIXED: Bob Noble Memorial Cup, presented by friends of Bob Noble.
- SENIOR MEN'S SINGLES: Walter M. Holdstein Memorial- Presented by Sportscraft & Ashaway.

## JUNIOR NATIONAL CHAMPIONSHIPS

THIRTEEN YEARS & UNDER

- Boys' Singles: Detroit Westwood Junior Badminton Club
- Girls' Singles: Dilwyne Badminton Club
- Boys' Doubles: Midwest Badminton Association  
Pasadena Badminton Club
- Girls' Doubles: Delaware Badminton Association  
Port Angeles Junior Badminton Club
- Mixed Doubles: Margaretta duPont Carpenter  
George R. Rackelin

FIFTEEN YEARS & UNDER

- Boys' Singles: Donald L. Ferris, Jr.
- Girls' Singles: Joanne, Jack and Mahlon Hessey
- Boys' Doubles: Raleigh and Gwen Hales  
Manhattan Beach Badminton Club Juniors
- Girls' Doubles: Delaware Badminton Association  
Connecticut Badminton Association
- Mixed Doubles: New Hampshire Badminton Association

EIGHTEEN YEARS & UNDER

- Boys' Singles: Missouri Badminton Association
- Girls' Singles: Donald Wilbur, Boston, Massachusetts
- Boys' Doubles: Massachusetts Badminton Association
- Girls' Doubles: Maryland Badminton Association
- Mixed Doubles, James F. Crafts, San Francisco, Calif.



ABA JUNIOR CHAMPIONS

## Sites of Junior National Championships:

1947	Baltimore, Maryland	1963	Philadelphia, Penn.
1948	New Britain, Conn.	1964	Pomona, Calif.
1949	Baltimore, Maryland	1965	Houston, Texas
1950	Boston, Massachusetts	1966	Philadelphia, Penn.
1951	Minneapolis, Minnesota	1967	Eugene, Oregon
1952	Niagara Falls, New York	1968	Newark, Delaware
1953	San Antonio, Texas	1969	Flint, Michigan
1954	Orange, New Jersey	1970	Manhattan Beach, Calif.
1955	Shaker Heights, Ohio	1971	Newark, Delaware
1956	Detroit, Michigan		
1957	Wilmington, Delaware		
1958	Burbank, California		

SINGLESBoys

1947	Ted Moehlmann, Jr.
1948	Ronnie Ryan
1949	Ronnie Ryan
1950	Steve Hinchcliffe
1951	Steve Hinchcliffe
1952	Jack Chrisman
1953	Don Davis
1954	Butch Kevorkian, Jr.
1955	Butch Kevorkian, Jr.
1956	Gary McFarlane
1957	Ted Ebenkamp
1958	Ted Ebenkamp
1959	Stan Hales
1960	Stan Hales
1961	Ray Park
1962	Paisan Loaharanu
1963	Robert Pritula
1964	Ken Fleming
1965	Ken Ferris
1966	Larry Saben
1967	Richard Neill
1968	Mike Walker
1969	Gary Higgins
1970	Charles Coakley
1971	Charles Coakley

Girls

Barbara Scarlett
Barbara Scarlett
Judy Devlin
Judy Devlin
Judy Devlin
Judy Devlin
Judy Devlin
Judy Devlin
Judy Devlin
McGregor Stewart
McGregor Stewart
Barbara Prince
Anne Erkkila
Patsy Hitchens
Sharon Pritula
Sharon Pritula
Tyna Barinaga
Caroline Jensen
Tyna Barinaga
Caroline Jensen
Janice DeZort
Susan Wilson
Chris Burton
Chris Burton
Polly Stockton
Pam Stockton



DOUBLES

	<u>Boys</u>	<u>Girls</u>
1947	Don Brown - Ted Moehlmann, Jr.	Barbara Scarlett - Sue Devlin
1948	Wilbur Bullen - Wm. Kellogg, III	Barbara Scarlett - Sue Devlin
1949	Jimmy Bishop - Ronnie Ryan	Judy Devlin - Sue Devlin
1950	Manuel Armendariz - Steve Hinchliffe	Judy Devlin - Deedy McCormick
1951	Dean Maurry - Jack Chrisman	Judy Devlin - Deedy McCormick
1952	Dean Maurry - Jack Chrisman	Judy Devlin Linda Cobb
1953	Don Davis - Dean Maurry	Judy Devlin Linda Cobb
1954	Butch Kevorkian, Jr. - Dick Ball	Rosine Capehart - Sally Thomas
1955	Butch Kevorkian, Jr. - Gary McFarlane	Nancy Metcalfe - Norma Slauer
1956	Bill Bryant - Russ Parquette	Norma Slauer - McGregor Stewart
1957	Ted Ebenkamp - Don Paup	Ardyce Carr - Virginia Green
1958	Ted Ebenkamp - Tom Trelloggen	Cynthia Dryden - Janet Ogilvie
1959	Stan Hales - Bill Foy	Helen Carter - Faith Ferris
1960	Pat Armendariz - Stan Hales	J. Shoepach - Sharon Pritula
1961	Pat Armendariz - Ray Park	Linda Erkkila - Barbara Bridges
1962	Richard Gorman - Bruce Mahler	Tyna Barinaga - Caroline Jensen
1963	Jay Collins - Ken Ferris	Tyna Barinaga - Caroline Jensen
1964	Ken Fleming - Larry Saben	Tyna Barinaga - Caroline Jensen
1965	Ken Fleming - Larry Saben	Caroline Jensen - Susan Wilson
1966	Ken Ferris - Larry Saben	Janice DeZort - Diane Moore
1967	Chris Kinard - Mike Walker	Susan Wilson - Judy Brodhun
1968	Chris Kinard - Mike Walker	Chris Burton - Ellen Van Os
1969	Bruce Pontow - Mike Adams	Polly Stockton - Pam Stockton
1970	Charles Coakley - Doug Bender	Polly Stockton - Pam Stockton
1971	Charles Coakley - Gary Higgins	Pam Stockton - Kay Roland



MIXED DOUBLES

- 1947 Pat Galbreath - Ted Moehlmann, Jr.
- 1948 Marilyn Banks - Ronnie Ryan
- 1949 Judy Devlin - Ronnie Ryan
- 1950 Judy Devlin - Ronnie Ryan
- 1951 Jean Gibbs - Steve Hinchliffe
- 1952 Joan Gibbs - Jack Chrisman
- 1953 Judy Devlin - Don Davis
- 1954 Linda Cobb - Butch Kavorkian, Jr.
- 1955 Norma Slauer - Butch Kavorkian, Jr.
- 1956 Marcia Dotson - Bill Bryant
- 1957 Barbara Prince - Ted Ebenkamp
- 1958 Cynthia Dryden - Ted Ebenkamp
- 1959 Sharon Pritula - Jack Keating
- 1960 Helen Carter - Stan Hales
- 1961 Sharon Pritula - Jim Lynch
- 1962 Joy Auxier - Paisan Loaharanu
- 1963 Caroline Jensen - Bruce Mahler
- 1964 Caroline Jensen - Ken Crow
- 1965 Janice DeZort - Larry Saben
- 1966 Janice DeZort - Larry Saben
- 1967 Susan Wilson - Richard Neill
- 1968 Chris Burton - Mike Walker
- 1969 Sandy Muthig - Bruce Pontow
- 1970 Diane Mies - Gary Higgins
- 1971 Diane Mies - Gary Higgins



## THE ABA NATIONAL CHAMPIONSHIPS

1937	- Chicago, Ill.	1963	- Baltimore, Md.
1938	- Philadelphia, Pa.	1964	- San Diego, Calif.
1939	- New York, NY	1965	- New Orleans, Louisiana
1940	- Seattle, Wash.	1966	- New Britain, Connecticut
1941	- Cleaveland, Ohio	1967	- Flint, Michigan
1942	- Durham, NC	1968	- Fullerton, Calif.
1943	- 1946 no competition	1969	- Natchitoches, Louisiana
1947	- Los Angeles, Calif.	1970	- Boston, Mass.
1948	- Waco, Texas	1971	- Las Vegas, Nevada
1949	- Chicago, Ill.		
1950	- Baltimore, Md.		
1951	- Dallas, Texas		
1952	- Seattle, Wash.		
1953	- Boston, Mass.		
1954	- Niagara Falls, NY		
1955	- Long Beach, Calif.		
1956	- Philadelphia, Pa.		
1957	- Spokane, Wash.		
1958	- Boston, Mass.		
1959	- Detroit, Mich.		
1960	- Hillside, Ill.		
1961	- Long Beach, Calif.		
1962	- Indiantown Gap, Pa.		

NATIONAL CHAMPIONS

## SINGLES

## Men

1937	Walter Kramer
1938	Walter Kramer
1939	David G. Freeman
1940	David G. Freeman
1941	David G. Freeman
1942	David G. Freeman
1943-1946	no competition
1947	David G. Freeman
1948	David G. Freeman
1949	Marten Mendez
1950	Marten Mendez
1951	Joe Alston
1952	Marten Mendez
1953	David G. Freeman
1954	Eddie Choon
1955	Joe Alston
1956	Finn Kobbero
1957	Finn Kobbero
1958	James Poole
1959	Tan Joe Hok

## Ladies

Mrs. Del Barkhuff (now Cunningham)
Mrs. Del Barkhuff (now Cunningham)
Mary E. Whitmore (now Mrs. L. Schlemm)
Evelyn Boldrick (Now Mrs. Nelson Howard)
Thelma Kingsbury (Now Mrs. Thelma K. Welcome)
Evelyn Boldrick
Ethel Marshall
Ethel Marshall
Ethel Marshall
Ethel Marshall
Ethel Marshall
Ethel Marshall
Ethel Marshall
Judy Devlin (Now Mrs. Hashman)
Margaret Varner (Now Mrs. Bloss)
Judy Devlin (Now Mrs. Hashman)
Judy Devlin (Now Mrs. Hashman)
Judy Devlin (Now Mrs. Hashman)
Judy Devlin (Now Mrs. Hashman)



SINGLES (Continued)

	<u>Men</u>	<u>Ladies</u>
1960	Tan Joe Hok	Judy Devlin (Now Mrs. Hashman)
1961	James Poole	Mrs. G.C.K. Hashman
1962	Ferry Sonnevile	Mrs. G.C.K. Hashman
1963	Erland Kops	Mrs. G.C.K. Hashman
1964	Channarong Ratanaseangsuang	Dorothy O'Neil
1965	Erland Kops	Mrs. G.C.K. Hashman
1966	Tan Aik Huang	Mrs. G.C.K. Hashman
1967	Erland Kops	Mrs. G.C.K. Hashman
1968	Channarong Ratanaseangsuang	Tyna Barinaga
1969	Rudy Hartono	Minarni
1970	CLOSED: Stan Hales OPEN: J. Honma	CLOSED: Tyna Barinaga OPEN: Etsuko Takenaka
1971	CLOSED: Stan Hales OPEN: Muljadi	CLOSED: Diane Hales OPEN: Noriko Takagi

DOUBLES

	<u>Men</u>	<u>Ladies</u>
1937	Chester Goss - Donald Eversoll	Mrs. Del Barkhuff (Now-Cunningham) Zoe Smith (Yeager)
1938	Hamilton B. Law - Richard O. Yeager	Mrs. Roy Bergman - Helen Gibson
1939	Hamilton B. Law Richard O. Yeager	Mrs. Del Barkhuff (Cunningham) - Zoe Smith (Yeager)
1940	David G. Freeman - Chester Goss	Elizabeth Anselm - Helen Zabriskie (Ough)
1941	David G. Freeman - Chester Goss	Thelma Kingsbury (Welcome) - Janet Wright
1942	David G. Greeman - Chester Goss	Evelyn Boldrick (Howard) - Janet Wright
1943	through 1946 no competition	
1947	David G. Freeman - Webster Kimball	Mrs Thelma Scovil (Welcome) - Janet Wright
1948	David G. Freeman - Wynn Rogers	Mrs. Thelma Scovil (Welcome) - Janet Wright
1949	Wynn Rogers - Barney McKay	Mrs. Thelma Scovil (Welcome) - Janet Wright
1950	Wynn Rogers - Barney McKay	Mrs. Thelma Scovil (Welcome) - Janet Wright



NATIONAL CHAMPIONS (Continued)

F - 2

DOUBLES - (Continued)

	<u>Men</u>	<u>Ladies</u>
1951	Wynn Rogers - Joe Alston	Mrs. Hulet C. Smith - Dottie Hann
1952	Wynn Rogers - Joe Alston	Ethel Marshall - Beatrice Massman
1953m	Wynn Rogers - Joe Alston	Judy Devlin (Hashman) - Susan Devlin (Peard)
1954	Ooi Teik Hock - Ong Poh Lim	Judy Devlin (Hashman) - Susan Devlin (Peard)
1955	Wynn Rogers - Joe Alston	Judy Devlin (Hashman) - Susan Devlin (Peard)
1956	Finn Kobbero - Jorgen Hammergaard Hansen	Ethel Marshall - Beatrice Massman
1957	Finn Kobbero - Jorgen Hammergaard Hansen	Judy Devlin (Hashman) - Susan Devlin (Peard)
1958	Finn Kobbero - Jorgen Hammergaard Hansen	Judy Devlin (Hashman) - Susan Devlin (Peard)
1959	Lim Day Hup - Teh Kew San	Judy Devlin (Hashman) - Susan Devlin (Peard)
1960	Finn Kobbero - Charoen Watansin	Judy Devlin (Hashman) - Susan Devlin (Peard)
1961	Wynn Rogers - Joe Alston	Mrs. G.C.K. Hashman - Mrs. Frank Peard
1962	Wynn Rogers Joe Alston	Mrs. G.C.K. Hashman - Mrs. <del>Clinton</del> Stephens
1963	Erland Kops - Robert McCoig	Mrs. G.C.K. Hashman - Mrs. Frank Peard
1964	Wynn Rigers - Joe Alston	Tyna Barinaga - Caroline Jensen
1965	Robert McCoig - Tony Jordan	Mrs. Margaret Barrand - Jennifer Pritchard
1966	Ng Boon Bee - Tan Yee Khan	Mrs. G.C.K. Hashman - Mrs. Frank Peard
1967	Joe Alston- Erland Kops	Mrs. G.C.K. Hashman - Mrs. R. Lemon
1968	James Poole - Don Paup	Mrs. Helen Tibbetts - Tyna Barinaga
1969	Ng Boon Bee - P. Gunalan	Retno Koestijah - Minarni
1970	CLOSED: Jim Poole Don Paup OPEN: I. Kojima J. Honma	CLOSED: Tyna Barinaga - Mrs. C. Hein OPEN: E. Takenaka - M. Aizawa
1971	CLOSED: Jim Poole - Don Paup OPEN: Ng Boon Bee - P. Gunalan	CLOSED: Mrs. R. Starkey - Mrs. C. Hein OPEN: Hiroe Yuki - Noriko Takagi



NATIONAL CHAMPIONS (Continued)

F - 3

MIXED DOUBLES

- 1937 Hamilton Law - Mrs Del Barkhuff (Wm. Cunningham)  
1938 Hamilton Law - Mrs. Del Barkhuff (Wm. Cunningham)  
1939 Richard O. Yeager - Zoe G. Smith (Yeager)  
1940 David G. Freeman - Sara Lee Williams (Mrs. G. Skibbins)  
1941 David G. Freeman - Sara Lee Williams (Mrs. G. Skibbins)  
1942 David G. Freeman - Sara Lee Williams (Mrs. G. Skibbins)  
1943 through 1946: No Competition  
1947 Wynn Rogers - Mrs. Virginia Hill (Mosdale)  
1948 Mr. & Mrs. Clinton P. Stephens  
1949 Wynn Rogers - Mrs. Hulet C. Smith  
1950 Wynn Rogers - Mrs. Hulet C. Smith  
1951 Wynn Rogers - Mrs. Hulet C. Smith  
1952 Wynn Rogers - Mrs. Charles Tibbetts  
1953 Mr. & Mrs. Joe Alston  
1954 Mr. & Mrs. Joe Alston  
1955 Wynn Rogers - Dorothy Hann  
1956 Finn Kobbero - Judy Devlin (Hashman)  
1957 Finn Kobbero - Judy Devlin (Hashman)  
1958 Finn Kobbero - Judy Devlin (Hashman)  
1959 Bunky Roche - Judy Devlin (Hashman)  
1960 Finn Kobbero - Margaret Varner (Bloss)  
1961 Wynn Rogers - Mrs. G.C.K. Hashman  
1962 Wynn Rogers - Mrs. G.C.K. Hashman  
1963 Sangob Rattanusorn - Mrs. Margaret Barrand  
1964 C. Ratanaseansaung - Mrs. Margaret Barrand  
1965 Robet McCoig - Mrs. Margaret Barrand  
1966 Wayne McDonnell - Tyna Barinaga  
1967 J.R. Sydnie - Mrs. G.C.K. Hashman  
1968 Larry Saben - Mrs. Rod Starkey  
1969 Erland Kops - Pernille Molgaard-Hansen  
1970 CLOSED: Jim Poole - Tyna Barinaga  
OPEN: Paul Whetnall - Margaret Boxall  
1971 CLOSED: Don Paup - Helen Tibbetts  
OPEN: Jim Poole - Maryann Breckell



SENIOR EVENTS

MEN'S SINGLES

1965 Dr. Charles Thomas  
1966 Dr. Charles Thomas  
1967 J. H. Butler  
1968 Richard Mitchell  
1969 John Leib  
1970 Ted Moehlmann, Jr.  
1971 Ted Moehlmann, Jr.

MIXED DOUBLES

1964 Larry Calvert - Jeanne Pons  
1965 Robert Love - Virginia Anderson  
1966 Dr. Waldo Lyon - Mrs. Helen Tibbetts  
1967 Robert Traquair - Ethel Marshall  
1968 Wynn Rogers - Mrs. Helen Tibbetts  
1969 Wynn Rogers - Ethel Marshall  
1970 Ted Moehlmann, Jr. - Ethel Marshall  
1971 Ted Moehlmann, Jr. - Ethel Marshall

LADIES DOUBLES

1958 Mrs. Al Kirby - Mrs. Thelma Welcome  
1959 Mildred Sirwaitis - Mrs. Mary Connor  
1960 Eleanor Coombs - Mrs. Hap Burdick  
1961 Mrs. Al Kirby - Charlotte Decker  
1962 Mrs. Al Kirby - Charlotte Decker  
1963 Eleanor Coombs - Mrs. Hap Burdick  
1964 Mrs. Al Kirby - Jeanne Pons  
1965 Ethel Marshall - Beatrice Massman  
1966 Mrs. Charles Tibbetts - Jeanne Pons  
1967 Ethel Marshall - Beatrice Massman  
1968 Ethel Marshall - Beatrice Massman  
1969 Ethel Marshall - Beatrice Massman  
1970 Ethel Marshall - Beatrice Massman  
1971 Mrs. Joe Alston - Mrs. Manny Armendariz



SENIOR EVENTS (Continued)

MEN'S DOUBLES

- 1938 H. Henriques - Georg McCook
- 1939 C.R. Hutchinson - Lealand Gustavson
- 1940 T.M. Royce - George McCook
- 1941 C. R. Hutchinson - Lealand Gustavson
- 1942 Lealand Gustavson - Frank N. Hinds
- 1943 through 1946: No Competition
- 1947 Lewis Rulison - ~~Hulet~~ C. Smith
- 1948 Frank N. Hinds - Fred Fullin
- 1949 Wayne Schell - Robert Wright
- 1950 Wayne Schell - Robert Wright
- 1951 Howard Holman - Fred Fullin
- 1952 Howard Holman - Fred Fullin
- 1953 Wayne Schell - Robert Wright
- 1954 Wayne Schell - Robert Wright
- 1955 Roy Lockwood - Dick Fleming
- 1956 Rupert Mee - Robert Traquair
- 1957 Carl Anderson - George Lane
- 1958 Wayne Schell - Robert Wright
- 1959 Robert Traquair - Ray Young
- 1960 Wayne Schell - Harold Seavey
- 1961 Wynn Rogers - Richard Mitchell
- 1962 Wynn Rogers - Dr. Waldo Lyon
- 1963 Bart Harvey - Charles Randolph
- 1964 Wynn Rogers - Dr. Waldo Lyon
- 1965 Wynn Rogers - Dr. Waldo Lyon
- 1966 B. Anderson - Robert Traquair
- 1967 Charles Randolph - Edward Spruill
- 1968 Wynn Rogers - Dr. Waldo Lyon
- 1969 Wynn Rogers - Lt Col Robert Gerzine
- 1970 Ted Moehlmann Jr. - J. L. McQuie
- 1971 Ted Moehlmann Jr. - J. L. McQuie



APPLICATION FOR MEMBERSHIP IN THE AMERICAN BADMINTON ASSOCIATION  
FOR CLUBS OR ASSOCIATIONS

Date: \_\_\_\_\_

To the ABA Board of Directors:

We, \_\_\_\_\_, President  
and \_\_\_\_\_, Secretary  
being duly authorized for the purpose, hereby apply, on behalf  
of the \_\_\_\_\_ Badminton { Club  
Association  
for membership in the American Badminton Association. We will  
observe and be bound by the rules of the Association.

Signatures \_\_\_\_\_, President

\_\_\_\_\_ Address

\_\_\_\_\_, Secretary

\_\_\_\_\_ Address

Number of members \_\_\_\_\_ Place and time of play \_\_\_\_\_

\*\*\*\*\*

Circle the type of membership for which this application is  
being made:      Regional Association = four or more clubs  
                    Independent Badminton Club = six or more adult members  
                    Dues @ \$1.75 per adult member;  
                    @ \$1.00 per junior (under 21) member

Make Checks payable to: AMERICAN BADMINTON ASSOCIATION and mail to  
Mrs. Virginia B. Lyon  
1330 Alexandria Drive  
San Diego, CA 92107



APPLICATION FOR INDIVIDUAL MEMBERSHIP ENROLLMENT IN THE AMERICAN  
BADMINTON ASSOCIATION

American Badminton Association  
1330 Alexandria Drive  
San Diego, California 92107

Gentlemen:

In order to play in ABA sanctioned tournaments,  
To have my tournament record considered for ranking,  
To receive the official ABA magazine, BADMINTON USA, as well as  
the official ABA Bulletin,  
To help promote badminton development in the USA,  
To help support USA teams in international competition,  
To support youth fitness and a lifetime sport for all ages,  
I hereby apply for Individual Membership in the ABA and enclose  
\$5.00 as my dues for the current season, or \$100.00 for a  
Lifetime Membership\*

Please Print or Type All Information

Mr.  
Mrs.  
Miss

\_\_\_\_\_

Last Name	First Name	Initial
-----------	------------	---------

Address: \_\_\_\_\_

Number	Street	City	State	Zip
--------	--------	------	-------	-----

\_\_\_\_\_  
(signature)

\* Make \$5.00 check payable to the ABA  
Make \$100.00 check payable to the U.S. Badminton Education  
Foundation



TOURNAMENT ENTRY BLANK:-SAMPLE

TOURNAMENT NAME		
Month	Days	Year
DATE		

CLASS OF TOURNAMENT: i.e. "A" & CONSOLATION, "B" & CONSOLATION

SPONSORED BY:

SANCTIONED BY:

CONDUCTED BY:

TO BE PLAYED AT:

TOURNAMENT COMMITTEE:

ELIGIBILITY & RANKING: Example- "A" and CONSOLATION TOURNAMENT-

All players are eligible regardless of ranking.  
 "B" and CONSOLATION TOURNAMENT-Only players who have been ranked "B" or "C" in an event will be eligible to compete in that event. Eligibility of any nonranked players will be determined by the tournament committee.  
 NOVICE FLIGHT - This flight reserved for unranked players and those who may be ranked "C", but have made little progress in the one or two tournaments entered. Eligibility will be determined by the tournament committee.

ENTRY DEADLINE: Entries must be postmarked by midnight, \_\_\_\_\_ or they will not be placed in the draw.

ADDITIONAL INFORMATION: Phone number of Tournament Chairman

CONDITIONS OF THE TOURNAMENT

1. The Tournament is open to all amateurs.
2. The Tournament will be conducted in \_\_\_\_\_ flights: "A" Flight and Consolation, "B" and Consolation, Novice
3. Players losing first round match in either "A" or "B" Flights will then play in Consolation round of that Flight with the exception of players who have been seeded by the Draw Committee.
4. Trophies will be awarded to all finalists in "A" Flight and "B" Flight and to winners of "A" Consolation, "B" Consolation, and Novice Flight.

Return Address  
Tournament Chairman

Stamp

Name and Address to whom  
Entry is being sent



5. The Tournament Committee will have the right to cancel any event in case there are insufficient entries.
6. The Tournament Committee reserves the right to alter the terms or dates of the Tournament and to reject the entry of any player for grounds which it may deem advisable.
7. Players must be ready to play at the time set for match or it will be necessary to default them unless delayed by another match. The 5 (15) minute default rule will be strictly enforced.
8. Players winning a match by default will be referred to the Tournament Committee for next match. A default on the first match does not eliminate the player from the Consolation Flight, should he lose the next match.
9. Decisions of Official Referee shall be final.
10. Umpires will be provided for every match.
11. Players are requested to wear all white clothing while on courts.
12. Play will be governed by the rules of the American Badminton Association.
13. An entry blank (or facsimile) must be sent for each individual entrant, accompanied by appropriate fee or the entry will not be placed in the draw.
14. Substitution of partners will not be allowed after the team has started the first match.
15. The Tournament Committee will make every effort to secure partners for those who so desire. If partner is not found, fee for the event will be refunded.
16. Players will be notified by mail as to times of their matches. Times of all matches will be posted on draw sheets at the tournament.
17. Players must be available for play from \_\_\_\_\_ P.M. Friday and from \_\_\_\_\_ A.M. Saturday if so scheduled.
18. Players must purchase tokens for shuttles before matches. One token per person will be required for every shuttle used in a doubles match; two tokens per person for every shuttle used in a singles match. Tokens will sell for 5/\$1.00 and will be collected by the Umpire before the match. (Note: This is a method that has kept tournaments from going in the red since the increase in shuttle costs.)

MAIL ENTRIES TO:

\_\_\_\_\_ Tournament Chairman, Address \_\_\_\_\_

MAKE CHECK PAYABLE TO:

\_\_\_\_\_

ENTRY FEES:

-----  
ENTRY BLANK (Limit - Three Events)

Name \_\_\_\_\_ Phone \_\_\_\_\_

Address \_\_\_\_\_

City \_\_\_\_\_ State \_\_\_\_\_ Zip \_\_\_\_\_

Club \_\_\_\_\_ School \_\_\_\_\_

Men's Singles	A _____	B _____	Total fee enclosed \$ _____
Ladies' Singles	A _____	B _____	
Men's Doubles	A _____	B _____	Partner
Ladies' Doubles	A _____	B _____	Partner
Mixed Doubles	A _____	B _____	Partner



## INDEX

1-65 refer to the page numbers of the General Text of this Handbook. (1)-(11) refer to the pages of the ABA Constitution. a-d refer to other Appendix items.

- Administration, 1
- Administrative Secretary, 1,2,3, 4,5-9,17,23,30,47,54
- Advertising Manager, Badminton USA, 22,23-25
- Age Requirements, 38,39-4-,44, 53,60
- Amateur Championships, See Championships
- Amateur Standing, 12,32,50,51,57, 59,60,(8)
- Amendments, (11)
- ABA Articles of Incorporation, 1
- ABA Bulletin, 1
- ABA Constitution, 1,(1)-(11)
- ABA Delegate to IBF, 34-35
- ABA Directors, 1,(3),(4)
- ABA Dues, 3,a,b
- ABA Emblem, 15,38
- ABA Handbook, 2,5,(10)
- ABA Match Scheduling, See Match Scheduling
- ABA Pins, 4,15,16
- ABA Rules Book, 1,33,
- ABA Secretaries, 5-9
- ABA Treasurer, 10-11
- Annual General Meeting, 5,(10)
- Annual Reports, 5,8,(9)
- Appeal, 13,(9)
- Applications, Membership, 3,a-b
- Apportion, 1,(4),(5)
- Approval, Shuttlecocks, 46-49
- Appreciation Award, Players', 20,B
- Articles of Incorporation, ABA, 1
- Associations, 3,4,38,39,(1),(2),a
- Association Members, (1),a
- Awards, 7,15-20,38, Recipients, B-F5
  
- Badminton Gazette, 3
- Badminton, News Committee, 42,(8)
- Badminton USA, 2,21-25, Advertising Manager, 23-25, Editor, 21-23, Operation Procedures, 21-25, Rates, 23
- Ballots, 9,19,(6),(10),(11)
- Bulletin, ABA, 1
  
- Certificates, Ranking, 45
- Championships, 50,51-57,(8), Age Requirements, 53, Junior, 39-40, National, 45,51-57, Shuttles for, 47-49
- Chairmen, ABA Committee, 1,(7)
- Classification, Tournament, 58-59
- Clubs,3(5),(6)
- Coach, International Teams, 36-37
- Committees, ABA, 1,5,18,20,45,(7)-(10), Chairmen, 1,(7)-(10)
- Constitution, ABA, 1,(1)-(11)
- Constitutional Secretary, 5,(3),(5)
- Court Specifications, 31-32
  
- Davidson, Ken, 17-19,38, Ballot, 19, Recipients, C
- Delegate, IBF, 34-35
- Development Participation Statement, 36,37,37.2,38
- Devlin Cup, 37A, 37.2
- Directors, ABA, 1,(3),(4)
- Donors, Perpetual Trophies, 16,D
- Draw, 33,53-54,60A-60B
- Dues, 3,(5)-(7),a,b
  
- Editor, 21,22,(7)
- Elections, 9,(11)
- Eligibility, for Awards, 18,20, Players, 31,32-33,38,39,40,44,60
- Emblems, ABA, 15,38
- Engraving, 17
- Entitling, 39,51
- Entry Cards, 39,51,c-d
- Event Commitment Statement, 36,37, 37.3,38
- Executive Committee, 1,5,13,16,17, 22,23,29,30,39,40,51,52,53,54, 55,(4),(5),(7),37
- Exhibitions, 50-51
- Expenses,10-11, International Teams, 37-37.1, Tournament, 54-55, Travel,1,53-54A,Membership, 3
  
- Fees, Shuttle Approval, 46, Sanction, 58
- Films, Library of, 26-28, Rental, 26-28, Request form, 28
- Finance Committee, 29-30
- Financial Responsibility for the Championships, 40,54
- Fiscal Year, (5),(7),(9),(11)
- Foreign Countries, Matches in, 51
- Foreign Players, 32,44
- Forms, Films, 28, Membership, a-b, Shuttles Bid Request, 47-48
  
- Gazette, Badminton, 3



General Administrative Secretary, Personnel, ABA, 1  
 1,2,3,4,5-9,17,23,30,47,54, Pins, ABA, 4,15,16  
 Groups, (5),(6) Players' Appreciation Award, 20,B  
 Guides, Rules & Regulations,1,2 Players', Eligibility,38,39-40,44,  
 42-43,54,60,31, Foreign,32,43,  
 Handbook, ABA, 2,5,(10), IBF,1,2 55-56, Travel expenses, 53-54  
 Helms Hall of Fame: See-United Policies,1, Sanction, 57  
 Savings Hall of Fame President, ABA, 1,5,6,16,18,21,22,  
 23,29,38,41,48,(3),(5)  
 Independent Clubs, (2),(6) Prohibited Activities, 12  
 Individual Members, 3,23,(2),b Proxy,(4),(10)  
 International Badminton Federation Publications, ABA,(10), Badminton  
 (IBF),1,2,5,31,33,34 USA,2,21-25, Bulletin, ABA, 1,  
 Invitations, Foreign Players, 32 Handbook, ABA,1,2, Rules Book, 1,  
 2,33,60  
 Junior Activities, 3,38-41,(9),  
 National Championships, 18,39-40  
 41,47,57, Awards, 38, Bids for, Qualifications for International  
 39, Champions, 15,38,E-E2, Players, 32-33  
 Shuttles,46,47, Rankings, 41, Quorum, (10)  
 Thomas & Uber Cup Teams, 38-39, Ranking, 22,41,43-45,57-58,(8),  
 Trophies,16,38, Other tourna- Certificates, 45, Listings,43  
 ments, 40-41, Development and Juniors, 41  
 Participation Statements, 38 Rate, Badminton USA, 23, Badminton  
 Gazette,3, Handbook, ABA, 2, IBF,  
 2, Rules Book, 2  
 Ken Davidson, 17-19,B Referees, 60  
 Laws of Badminton, 3,31,33 Regions, ABA, 43,(3)-(4)  
 Library, Film, 26-28 Regional Associations, See: Assoc.  
 Linesmen, 60 Regulations, 1  
 Reinstatement, 12  
 Magazine, Badminton USA, 2,21-25, Reports to Members, 1,3, to Pres-  
 Badminton Gazette, 3 ident, (9)  
 Match Scheduling, ABA, 40,43,54, Request forms for Films, 28  
 60,61-65 Responsibility, Financial, 40,54,  
 60,61-65 Perpetual Trophies,16-17  
 Meetings, (10) Results, Tournament, 41,60  
 Membership, ABA, 1,3,5,32,(1),(2), Rules, 1,12  
 (8), Applications,3,a-b, Rules Book, 1,2,33,60, Committee,  
 Associations, 38,39,(1),(2),(3), 2,33,(8)  
 a, Clubs,(2),s, Groups,(2),a Rules, Regulations, Policies,1  
 Individuals,(2),b, Students & Sanction, Tournament,22,40,57-59.  
 Juniors,3 (8), Fees,58, Deadline,59,  
 Members, 1,3, Reports to, 3,5 Penalties, 59  
 Name, ABA,(1) Scheduling, ABA Match,40,43,54,60,  
 National Championships, 9,18,31- 61-65  
 33,45,51-57, Champions, 15,45, Season, Tournament, 41,43  
 (10),F-F5, Secretary, Constitutional, 1,5,(3),  
 Juniors, 15,39-40,E-E2, Shuttles (5), General Administrative,1,2,  
 for, 47-49, Trophies for,16-17 3,4,5-9,17,23,30,47,54, Secretary-  
 News, National Badminton, 42,(8) Treasurer,(3),(5)  
 Nominations, (9),(11) Seeding,33,45,53-54,60B-60C  
 Objectives, ABA, (1),(10) Shuttlecocks, 32,46-49A,(8),  
 Official Publications, 1,21,(10) Adoption for National Champion-  
 Official Rules Book, 1,2 ships, 47  
 Officers, ABA, 1,(5),A-A1 Special Awards, 17-20  
 Officiating, 60 Students, 3  
 Perpetual Trophies, 16, Donors, Team Point System, 60  
 D, Winners, D-F5 TV, 55



Thomas Cup, 4, 16, 30, 32, 36-37.3,  
38-39, 42, (8)-(9), Juniors, 38-39  
Tournaments, 50-65, (8), Bids, 39,  
52, Classification, 58-59, Draw,  
60, Entry, 39, 51, c-d, Juniors, 40,  
Results, 60½, Sanction, 57-60,  
Scheduling, 61-65, Seed, 60, 60B-  
60C, Shuttles for, 46, Team  
Point System, 60  
Traveling Expenses, 1, 5, 51, 53-54  
Treasurer, 1, 10-11, 22, 29, (3), (5)  
Trophies, 7, 16-17, Donors, D,  
Engraving, 17, Perpetual 16,  
Responsibility for, 16-17  
Tryouts, International Teams, 36-  
37.1

Uber Cup, 3, 16, 30, 32, 36-37.3, 38  
42, (9)  
Umpires, 60  
United Savings Helms Hall of Fame,  
19, 20, Recipients, B

Voting, 1, 9, (5)-(7), (11)

Winners, Awards, 15, National  
Champions, 45, Juniors E-E2,  
Adults, F-F5



