

Mr. Stan Hales
1143 Yale Ave.
Claremont, CA 91721

A M E R I C A N B A D M I N T O N A S S O C I A T I O N



1 9 6 8 - 1 9 6 9

G U I D E S , R U L E S A N D R E G U L A T I O N S

1968 - 1969

GUIDES, RULES AND REGULATIONS

of

THE AMERICAN BADMINTON ASSOCIATION

ABA OFFICERS AND DIRECTORS 1968-1969

President	Taylor Caffery 1805 NBC Building, New Orleans, LA 70112
1st Vice-Pres.	William Goodman 26 Sagamore Rd., Wellesley, MA 02181
2nd Vice-Pres.	Mrs. Helen Tibbetts 6645 S. Holt Ave., Los Angeles, CA 90056
Secretary	Miss Betty Brown 1640 Dufossat St. D, New Orleans, LA 70115
Treasurer & Administrative- Secretary	Mrs. Virginia B. Lyon 1330 Alexandria Dr., San Diego, CA 92107
Immediate Past President	Dr. Waldo K. Lyon 1330 Alexandria Dr., San Diego, CA 92107

DIRECTORS

Region 1-New England

John Cooper - 25 Fostmere Court, Warwick, RI 02889
Lester Hilton - 15 Tanglewood Dr., Cumberland, RI 02864
Donald Lumsden - 64 Pond St., Needham, MA 02192
Harold Smith - 233 Clark Ave., Short Beach, CT 06405

Region 2-Middle Atlantic

John Cornell - 225 Port Royal Ave., Philadelphia, PA 19128
Frank Devlin - Dolfield Rd., Owings Mills, MD 21117
Amerigo Domestico, Jr. - 36 86th St., Brooklyn, NY 11209
Harvey Snavely - 2104 Water St., Lebanon, PA 17042

Region 3-Southern

Dr. J. Breen - P.E. Dept., Tulane U., New Orleans, LA 70118
Mark McGarry, Jr. - P.O. Box 811, St. Petersburg, FL 33731
Dr. C. Thomas - Box 1026 NWLA State College, Natchitoches,
LA 71457

Region 4-Midwest

Mrs. Thelma Burdick - 1907 N. Normandy Ave., Chicago, IL 60635
Cletus Eli - 6303 S. Linden Rd., Swartz Creek, MI 48473
Robert Petz - 111 Lakeshore Rd., Grosse Pointe Farms, MI 48236
Robert Rahr - 1406 W. Taylor, Appleton, WI 54911

Region 5-Western

Dr. Virginia Hicks, Box 3717 TWU Station, Denton, TX 76214
Edward Stuart - Friendswood, TX 77546

Region 6-Pacific

Richard Ferrell - 1615 N. 197th Pl., Seattle, WA 98133
Phil Janz - 155 34th Place East, Eugene, OR 97405
Richard Mitchell - 4441 Reville Dr., San Diego, CA 92115
Jack van Praag - 905 S. Los Robles, Pasadena, CA 91106

1968 - 1969 COMMITTEE CHAIRMEN

Amateur Status--Donal O'Callaghan, 75 Federal St., Boston,
Mass. 02110
Junior Activities--Stan Hales, 1143 Yale Ave., Claremont,
Calif. 91711
Membership--Jim Poole, P.O. Box 21451, University Station
Baton Rouge, LA 70803
National Badminton News--Jack van Praag, 905 S. Los Robles,
Pasadena, Calif. 91106
Nominating--Wm. Parsons, 1120 12th Ave., Altoona, Penn. 15601
Ranking & Tournament Sanction--Cletus Eli, 6303 S. Linden Rd.
Swartz Creek, Mich. 48473
Rules--Les Hilton, 15 Tanglewood Drive, Cumberland, RI 02181
Shuttlecocks--Howard Eissler, 325 N. 29th St., Camp Hill
Penn. 17011
Thomas Cup-- William Goodman, 26 Sagamore Rd., Wellesley
Mass. 02181
Uber Cup--Mrs. Helen Tibbetts, 6645 S. Holt Ave., Los Angeles
Calif. 90056
1969 U.S. Open Championships--Dr Charles Thomas, Box 1026,
NWLA State College, Natchitoches, LA 71457
1969 Junior Championships--Mrs. Lynn Stockton, 631 E. Atherton R
Flint, Mich. 48507
BADMINTON USA Editor--Mrs. Grace Devlin, Dolfield Rd.
Owings Mills, MD 21117
Finance--Robert Petz, 111 Lakeshore Rd., Grosse Pointe Farms
Mich. 48236
Handbook--Tim Royce, Smith Tower Bldg., Seattle, Wash. 48236
Helms Hall of Fame Selection--Miss Ethel Marshall, 187 Delamere
Williamsville, NY 14221
Intercollegiate & Interscholastic--Dr. James Breen, Dept of P.E.
Tulane U., New Orleans, LA 70118
IBF Representative--Ted Jarrett, 1720 Humbolt Ave.,
So Minneapolis, Minn. 55403
Mrs. Judy Hashman, 20 Sandleigh Rd.,
Cooton nr. Abington, Berkshire, England
Legal--Charles Newhall, 75 Federal St., Boston, Mass. 02110
International Match--Miss Beatrice Massman, 333 Saratoga Rd.
Buffalo, NY 14226
Miss Ethel Marshall, 187 Delamere Rd.
Williamsville, NY 14221

This 1968-1969 "Guide, Rules and Regulations of The American
Badminton Association" is available for \$2.00 per copy from

Mrs. Virginia B. Lyon
1330 Alexandria Drive
San Diego, CA 92107

CONTENTS

CONSTITUTION		1
I. Name	1	
II. Objectives	1	
III. Membership	1	
IV. Associations	2	
V. Board of Directors	3	
VI. Officers	5	
VII. Dues and Voting	5	
VIII. Committees	6	
IX. Official Publication	8	
X. Meetings	9	
XI. Miscellaneous	10	
XII. Amendments	10	
ADMINISTRATION		11
Personnel	11	
Rules, Regulations, & Policies	11	
Official Publications	11	
ABA Handbook	12	
Badminton USA	12	
Official Rules Book	12	
IBF Handbook	12	
Members	13	
ABA Pins	13	
AMATEUR STANDING RULES		14
Definition	14	
Expenses	14	
Prohibited Activities	14	
Reinstatement	14	
Interpretation*	14	
APPEAL TO EXECUTIVE COMMITTEE OR BOARD OF DIRECTORS		15
AWARDS		16
ABA Emblems	16	
ABA Pins	17	
ABA Trophies	17	
Special Awards	18	
INTERNATIONAL BADMINTON		21 A
National Open Championships	21 A	
JUNIOR ACTIVITIES		24
Junior Awards	24	
Junior Thomas and Uber Cup Teams	24	
National Junior Championships	25	
Other Junior Tournaments	26	
Ranking	27	

ii Contents

RANKING		28
Administrative Procedure	28	
Ranking Lists	28	
Eligibility	29	
Committee Responsibility	29	
1968-1969 National Rankings	30	
REFEREES, UMPIRES AND LINESMEN		32
Duties of Referee	32	
Duties of Umpire	32	
Duties of Linesman	34	
Duties of Service Court Judge	34	
SHUTTLECOCKS APPROVAL AND ADOPTION		35
Approval of Shuttlecocks for Tournament Play	35	
National Championships Adoption	36	
TOURNAMENTS & EXHIBITIONS		38
Championships	38	
Exhibitions	38	
National Championships	39	
Sanctions	43	
Actual Conduct of Tournament	45	
The Draw	47	
Seeding The Draw	48	
ABA Match Scheduling	50	
APPENDIX		
Membership Enrollment Application	a	
Regional Sanction Chairmen 68-69 Season	c	
Tournament Entry Blank - Sample	d	
Acknowledgement of Perpetual Trophy	e	

INDEX



AMERICAN BADMINTON ASSOCIATION

CONSTITUTION

of the

AMERICAN BADMINTON ASSOCIATION

Revised 1968

To become effective July 1, 1968

ARTICLE I. NAME

Section 1. This Association, organized July 1936, and incorporated under the laws of the State of Illinois, August 15, 1938, shall be called the AMERICAN BADMINTON ASSOCIATION, hereinafter referred to as the ABA.

Section 2. The ABA is a member association [elected to membership July 19, 1938] of the International Badminton Federation, hereinafter referred to as the IBF.

ARTICLE II. OBJECTIVES

The objectives of the ABA are:

1. To promote and develop the game of badminton in the United States without the purpose of monetary gain; to assist in the development of clubs and associations in the United States; to establish and uphold rules of play and to determine the status of players in the United States, and to arrange and manage national tournaments in the United States; and to sanction regional, sectional, state, city and other local tournaments in the United States.
2. To act as the United States authority in any international tournaments; to choose and manage teams representing the United States in international competition; to represent the United States interest in international badminton decisions and activities of the IBF.
3. To promote programs developing badminton as a means of healthful recreation, physical and mental fitness, including carryover benefits of badminton as a life-time sport.
4. In order to promote these objectives, to accept, manage and use property of any kind in any manner not prohibited by law to corporations of the type and character of the ABA.

ARTICLE III. MEMBERSHIP

There shall be three [3] classes of members, as follows:

Section 1. ASSOCIATION MEMBERS. Association members shall be those associations now in existence or hereafter formed and which are referred to in Article IV, Section 1 hereof, and which pay the dues prescribed for Association Membership.

Section 2. CLUB/GROUP MEMBERS. Club/Group Members shall consist of:

{a} any club or organized group {e.g. any private club, YMCA, YWCA, public recreation and other government department, church, educational institution, camp, armed service branch or group, etc.} which is interested in the promotion of badminton in any manner, and in accordance with the rules of the ABA and IBF, which is a club or group member of the Association Member within the boundaries of which it is located and which has paid the dues prescribed for membership in such association; and
 {b} any such club or group located outside the boundaries of any Association Member which shall have paid the dues prescribed for Club/Group Membership in the ABA and which includes in its membership at least six {b} individuals of whom at least three {c} are 19 or more years of age.

Section 3. INDIVIDUAL MEMBERS. Individual Members shall be divided into the following four {4} classes:

{a} CLASS 1 MEMBERS. Individual, 19 years or older, may become a Class 1 Member of the ABA upon application and payment of annual dues prescribed for Class 1 Membership.

{b} CLASS 2 MEMBERS. Any individual, under 21 years of age, may become a Class 2 Member of the ABA upon application and payment of annual dues prescribed for Class 2 Membership.

{c} CLASS 1 LIFE MEMBERS. Any individual, 19 years or older, may become a Class 1 Life Member of the ABA upon application and payment of one lump sum payment prescribed for Class 1 Life Membership, which shall continue during his {or her} lifetime and shall not continue after his {or her} death for the benefit of any member of his {or her} family.

{d} CLASS 2 LIFE MEMBERS. Any individual, under 19 years of age, may become a Class 2 Life Member of the ABA upon application and payment of one lump sum payment prescribed for Class 2 Life Membership. Upon reaching his {or her} 19th birthday, each Class 2 Life Member shall automatically, without additional payment, become a Class 1 Life Member.

ARTICLE IV. ASSOCIATIONS

Section 1. The Association Members of the ABA shall be Associations composed of local Club/Groups and /or individuals in areas within one of the respective Regions set forth in Section 2, Article V, provided that:

{a} There shall not be more than one Association covering the same area {which areas may constitute part or all of any Region};

{b} such Association shall have been recognized as an affiliate of the ABA either {1} by the provisions of Section 2 of this Article IV or {2} subsequently by vote of the Board of Directors; and

{c} the organization, objectives, bylaws and procedures of the Association are deemed by the Board of Directors of the ABA to be in keeping with this Constitution and with the appropriate rules and regulations of the IBF.

Section 2. Recognized Associations as of the date of the adoption of this Constitution in its present form are:

Region 1.

Connecticut Badminton Association
 Massachusetts Badminton Association
 New Hampshire Badminton Association
 Rhode Island Badminton Association

Region 2.

Delaware Valley Badminton Association
 Maryland Badminton Association
 Metropolitan Badminton Association
 Western New York Badminton Association

Region 3.

Southern Badminton Association

Region 4.

Midwest Badminton Association

Region 5.

Southwestern Badminton Association

Region 6.

Northern California Badminton Association
 Oregon Badminton Association
 Southern California Badminton Association
 Washington State Badminton Association

Section 3. Local clubs, groups and/or individuals forming an additional or revised Association may be recognized by the Board of Directors, consistent with the provisions of Section 1 of this Article IV, as additional or revised Associations following the filing of a petition for such recognition with the Membership committee as contemplated by Paragraph 4 of Section 3 of Article VIII hereof.

ARTICLE V. BOARD OF DIRECTORS

Section 1. The active management of the ABA shall be vested in a Board of Directors.

Section 2. Effective 1 July 1969, the Board shall consist of the President, the Vice-Presidents, the Immediate Past President, the Secretary-Treasurer (or the Secretary and the Treasurer, as the case may be) and thirty (30) Directors representing the following six (6) Regions of the United States:

Region 1. {New England}: Connecticut, Maine, Massachusetts, New Hampshire, Rhode Island, Vermont;

Region 2. {Middle Atlantic}: Delaware, District of Columbia, Maryland, New Jersey, New York, Pennsylvania, West Virginia;

Region 3. {Southern}: Alabama, Arkansas, Florida, Georgia, Louisiana, Mississippi, North Carolina, South Carolina, Tennessee, Virginia;

Region 4. {Midwestern}: Illinois, Indiana, Iowa, Kentucky, Michigan, Minnesota, Missouri, Ohio, Wisconsin;

Region 5. {Western}: Colorado, Kansas, Montana, Nebraska, New Mexico, North Dakota, Oklahoma, South Dakota, Texas, Utah, Wyoming;

Region 6. {Pacific}: Alaska, Arizona, California, Hawaii, Idaho, Nevada, Oregon, Washington;

Section 3. Each Director shall be elected by the Association, Club/Group, Class 1, Class 1 Life, Class 2, and Class 2 Life Members within or affiliated with the Region which he {or she} represents. Each Director must be a Class 1 or Class 1 Life Member residing within the Region which he {or she} represents.

Section 4. Each Director shall be elected for a two-year term and shall continue to serve out the term, provided he {or she} continues to be a Class 1 or Class 1 Life Member residing within the Region which he {or she} represents. Terms of office shall be set such that one half of the Board of Directors is elected on alternate years.

Section 5. Each year, the Executive Committee shall apportion the Directorships to be filled among the six {6} Regions. Each Region shall be entitled to that proportion of the thirty {30} Directors as the aggregate number of votes represented by the ABA Membership in such Region of all classes bears to the aggregate number of votes represented by the entire ABA Membership of all classes {all as ascertained by the Secretary-Treasurer, or Secretary, as the case may be}; provided, always, that each Region must have at least two {2} Directors. Fractional adjustments required in connection with Directorships shall be determined by the Executive Committee. Apportionment of Directorships to be filled each 1 July shall be based on the aforesaid Membership as of the end of the prior fiscal year.

Section 6. If the office of any elected Director becomes vacant by reason of death, resignation, election to the office of President or Vice-President, or appointment to the office of Secretary-Treasurer {or Secretary or Treasurer}, disqualification or inability to act, the President may appoint a successor for the unexpired term subject to the qualification requirements of Section 3 of this Article V and to ratification of such appointment by an affirmative vote of two-thirds {2/3} of the members of the Board of Directors.

Section 7. Each Director shall have the right to designate a proxy from his {or her} own Region to attend any regular or special meeting of the Board of Directors and to vote thereat in his {or her} place. Any such proxy must be a Class 1 or Class 1 Life Member within such Region and shall have the full right to participate in a regularly called meeting of the Board of Directors, including the right to vote; provided, however, that no person shall be entitled to hold more than one proxy at any meeting.

Section 8. Irrespective of requirements specified in Sections 2, 3, 4, 5, and 6 of this Article V, any Director who was elected prior to 1 July 1968 shall finish out the term for which he {or she} was originally elected, except that to continue in office after 1 September 1968, he {or she} must become and maintain a Class 1 Life or Class 1 Membership.

Section 9. The Executive Committee, by 20 January 1969, shall determine the number of Directorships to be filled to raise the total number to thirty {30} as of 1 July 1969 and apportion them in accordance with Section 5 of this Article V, taking into account the regional affiliations of all Directors holding over to 30 June 1970.

ARTICLE VI. OFFICERS

Section 1. The officers of the ABA shall consist of a President, a First Vice-President, a Second Vice-President, and, as the President shall determine as to any fiscal year, either {a} a Secretary-Treasurer, or {b} a Secretary and a Treasurer.

Section 2. The term of office of the President shall be two years, and of each Vice-President one year. Each of said terms of office shall coincide with the fiscal years or year or until such time as the officer is succeeded in his {or her} office by an officer duly elected under provisions of Section 6 and 7 of Article X. The President shall be elected biannually in each even year by majority vote of the Board of Directors. The Vice-Presidents shall be elected annually by a majority vote of the Board of Directors. To be eligible for election as President, or as a Vice-President, the individual must be a Class 1 or Class 1 Life Member. In addition, to be eligible for election as President, the individual must have served at least two years as a Vice-President and/or Director. Not more than one such officer shall be a Member residing within Regions 1 and 2, nor more than one shall be a Member residing within Regions 3 and 4, nor more than one shall be a Member residing within Regions 5 and 6.

Section 3. The Secretary-Treasurer {or the Secretary and Treasurer, as the case may be} shall be appointed by the President with the approval of the Board of Directors. The term of office shall coincide with the fiscal year.

Section 4. The President shall be the chief executive officer of the ABA and shall preside at all meetings of the ABA and all meetings of the Board of Directors. He {or she} shall be, by virtue of his {or her} office, a member of all committees of the ABA except, if one be appointed, the Auditing Committee.

Section 5. The Secretary-Treasurer {or the Secretary and Treasurer each, as the case may be} shall be directly responsible to the Directors for the usual duties incident to their respective offices.

ARTICLE VII. DUES AND VOTING

Section 1. Each Association Member, each individual Member and each Club/Group Member referred to in Article III, Section 2, paragraph {b} shall pay annual dues to the ABA in an amount to be determined annually by the Executive Committee of the ABA subject to approval of the Board of Directors, provided that, each Life Member shall make one lump sum payment to the ABA in an amount to be determined from time to time by the Executive Committee subject to approval of the Board of Directors.

Section 2.

{a} Each ABA Association Member shall be entitled to one vote for each member of each Club/Group Member belonging to such Association. Ballots required in connection with Association voting shall be mailed by the ABA Secretary to the Association presidents. The Association shall conduct the balloting and report the result to the ABA Secretary.

{b} Each Club/Group Member not a member of any such Association shall be entitled to one vote for each member of such Club or Group. Ballots for use by Club/Group Members referred to in this paragraph {b} shall be mailed by the ABA Secretary to such Club/Group Member, which Club/Group Member shall conduct the balloting and report the result to the ABA Secretary.

{c} Each individual Member shall be entitled to one vote. Ballots for individual Members shall be mailed by the ABA Secretary to each such Member, who shall cast the ballot with the ABA Secretary.

Section 3. The Membership year of the ABA shall be its fiscal year as hereinafter fixed by Section 1 of Article XI. All Memberships except Life Memberships shall expire each 30 June. Membership becomes effective upon receipt of dues {a} by the Secretary of the ABA, or {b} by such other person or persons as shall have been authorized to receive the same by said Secretary or by the President of the ABA.

ARTICLE VIII. COMMITTEES

Section 1. The President, the Vice-Presidents, the Immediate Past President, and the Secretary-Treasurer (or the Secretary and the Treasurer, as the case may be) shall constitute the Executive Committee for the administration of the affairs of the ABA. The editor of the official publication of the ABA shall be a non-voting, ex-officio member of the Executive Committee.

Section 2. In addition to special committee chairmen who may be appointed from time to time, the President shall appoint the Chairmen of the standing Committees referred to in Section 3 of this Article VIII, with the advice and consent of the Board of Directors, and may appoint the members of each such Committee {with the advice and consent of the Board of Directors} if he elects to do so, provided, always, that if and to the extent that the President does not so elect, the members of any such Committee shall be appointed by the Chairman of the Committee, with the advice and consent of the Board of Directors.

Section 3. Standing Committees and the respective duties of each are:

{1} Rules Committee. It shall be the duty of this Committee to uphold the rules of play as established by the IBF; to be the arbiter on all points of dispute, and to be responsible, if and when required for the establishment and operation of an Umpires' Association.

- {2} Amateur Status Committee. It shall be the duty of this Committee to determine whether or not individuals entered in sanctioned tournaments are amateurs. The Committee shall develop, and from time to time perfect, a code for the guidance of its sub-committee for the interpretation of the rules for amateur standing. The Committee shall have the authority to make such rulings on both the eligibility and reinstatement of individuals as may be necessary and proper in the administration of the rules of amateur standing.
- {3} Ranking and Tournament Sanction Committee. It shall be the duty of this Committee to determine the national ranking of players and report their findings to the Secretary annually ninety {90} days after completion of the National Championships {Senior}. It shall also have authority to sanction all ABA recognized regional, sectional, state and local tournaments and exhibitions.
- {4} Membership Committee. It shall be the duty of this Committee:
- {a} to promote and assist the orderly establishment of Associations;
 - {b} to recommend to the Board of Directors the affiliation of new or changed Associations; and
 - {c} to recommend organizational and/or financial assistance that should be given to any Association.
- {5} Championships Committee. It shall be the duty of this Committee to manage and supervise the Annual National Championships, working in co-operation with such local committees as may be appointed.
- {6} Badminton News Committee. It shall be the duty of this Committee to promote publicity pertaining to the development of the game, co-operating at all times with the staff of the official publication of the ABA.
- {7} Shuttlecock Committee. It shall be the duty of this Committee to test shuttlecocks and determine their eligibility for tournament play and to select the one used in each National Championships.
- {8} Thomas Cup Committee. It shall be the duty of this Committee:
- {a} to manage all operations pertaining to training and selection of players for the international competition for the Thomas Cup;
 - {b} to be responsible to the Board of Directors for the operation of any Thomas Cup ties held in this country, or for the details of arrangements of such ties if held in other countries, as they pertain to the United States team;
 - {c} to develop and operate a program for the furtherance of Thomas Cup teams, under the approval of the Board of Directors or the Executive Committee of the ABA. The Chairman of the Ranking and Tournament Sanction Committee shall automatically be a member of this Committee.

- {9} Uber Cup Committee. It shall be the duty of this Committee:
- {a} to manage all operations pertaining to the training and selection of players for the international badminton competition for the Uber Cup;
 - {b} to be responsible to the Board of Directors for the operation of any Uber Cup ties held in this country, or for the details of arrangements of such ties, if held in other countries, as they pertain to the United States team; and
 - {c} to develop and operate a program for the furtherance of Uber Cup teams, under the approval of the Board of Directors or Executive Committee of the ABA. The Chairman of the Ranking and Tournament Sanction Committee shall automatically be a member of this Committee.
- {10} Junior Activities Committee. It shall be the duty of this Committee to promote and develop junior play, establish national rankings of juniors and co-operate with the Championships Committee in conducting the National Junior Championships.
- {11} Nominating Committee. So far as feasible, this Committee shall consist of one Member from each of the ABA Regions. It shall be the duty of this Committee to nominate Directors as necessary for election each year. Its report shall be submitted in writing to the Secretary fifty {50} days prior to the Annual General Meeting of the ABA and such report shall be sent to every Member as defined in Article III hereof thirty {30} days before the Annual General Meeting.
- It shall also be the duty of this Committee each year to inquire of the President of each Association Member within each Region with respect to which a director is to be elected who he suggests as such Director. It shall likewise be the duty of this Committee, if requested to do so by the Executive Committee, to submit to such Executive Committee, for transmittal to members of the Board of Directors, a list of suggested nominees for offices to be filled by election by the Board of Directors as provided in Section 7 of Article X.

Section 4. All Committees listed in Section 3 of this Article VIII shall serve for the fiscal year of the ABA and until their successors are appointed. Each Committee Chairman shall make an annual report to the President prior to 1 July each year.

Section 5. Any Member {including any member of any member clubs or groups} shall have the right to appeal the decision of a Committee to the Executive Committee or to the Board of Directors.

Section 6. Committee Rules and Regulations shall be published in the ABA HANDBOOK, reviewed from time to time by the Committee Chairmen and the Board of Directors, and may be changed by vote of the Board of Directors.

ARTICLE IX. OFFICIAL PUBLICATION

There shall be an official publication of the ABA which, as issued,

shall be sent to each of the following Members; {all as defined in Article III}: {1} Association, {2} Club/Group, {3} Individual. The editor shall be appointed by the President, subject to the approval of the Executive Committee, and each shall serve until his {or her} successor is appointed. The editor shall be an ex-officio member of the Executive Committee with no voting privilege.

ARTICLE X. MEETINGS

Section 1. An Annual General Meeting shall be held in conjunction with the National Championships {Senior} at such time and place as is determined by the Board of Directors, at least thirty {30} days' notice thereof to be given by mail to the voting Membership by the Secretary-Treasurer {or Secretary, as the case may be}.

Section 2. The Annual Meeting of the Directors shall be held in conjunction with the National Championships {Senior} in such manner and place as is determined by the President. At least thirty {30} days' notice of such meeting, and of any other meeting of the Directors to be held in person, shall be given by mail to each member of the Board of Directors by the Secretary-Treasurer {or Secretary, as the case may be}.

Section 3. Other meetings of the Directors shall be held in September, November, January and June, and may be held either in person or by mail as may be arranged by the President.

Section 4. Special meetings of the Directors may be called by the President at any time and must be called by him upon request of five Directors.

Section 5. Quorum. A quorum for the conduct of business at the Annual General Meeting shall consist of those present in person or by proxy representing 5% of the total number of votes entitled to be voted at the meeting. Except in the case of an amendment to this Constitution, a balloting by mail shall be determined by a majority of the votes or applicable ballots recieved within such time as is designated therfor on the ballot, whatever percent of the total voting Membership shall have voted. A vote for an amendment of this Constitution shall be deemed to have been duly adopted if two-thirds of the votes received within forty {40} days after the Annual General Meeting to which the amendment has been submitted are in favor thereof. A quorum for the conduct of business at meeting of the Board of Directors shall be twelve {12}, of which eight{8} must be present in person.

Section 6. Nominations. At the Annual General Meeting, the Chairman of the Nominating Committee shall present the Committee's nominations for Directors, following which nominations from the floor shall be in order until declared closed by the President. {a} Each floor nomination for Director shall be in writing, giving the name of the nominee, his {or her} signature indicating acceptance, the Region he {or she} represents, and signatures of at least five Members residing within such Region who endorse the nomination.

{b} To be eligible for nomination as a Director, an individual must meet the qualifications of Section 3, Article V. The Secretary-Treasurer {or the Secretary, as the case may be} shall certify that each nominee fulfills the eligibility requirements appropriate in each case and that each endorser is a Member residing within the appropriate region.

Section 7. Ballots for election of Directors shall be mailed to each voting Member, as defined in Article VII, Section 2, before 1 May of each year, to be returned to the Secretary-Treasurer {or the Secretary, as the case may be}. The election shall close midnight 1 June. The Board of Directors for the ensuing fiscal year {newly elected and non-retiring Directors} shall then elect the officers {President biannually, Vice-Presidents annually} by mail ballot sent to each Director before 5 June. The election of officers shall close midnight 30 June. If as to any one of the officers, no candidate obtains a majority of votes received by midnight 30 June, a run-off ballot shall be mailed immediately listing the two candidates receiving the largest and next largest number of votes. The run-off election shall close midnight 30 July.

ARTICLE XI. MISCELLANEOUS

Section 1. The fiscal year shall begin 1 July of the year.

Section 2. Membership in the ABA, as defined in Article III, becomes effective 1 July 1968.

ARTICLE XII. AMENDMENTS

Section 1. Any proposed amendment to this Constitution must be endorsed by at least {5} individual Members or by the Executive Committee, or by any Association Member and shall be submitted in writing to the Secretary-Treasurer {or the Secretary as the case may be} at least fifty {50} days prior to the Annual General Meeting, and copies shall be mailed to each voting Member, as defined in Article VII, Section 2, at least thirty {30} days before such meeting.

Section 2. Votes on amendments to this Constitution shall be adopted only by mail vote pursuant to Section 5 of Article X hereof.

RULES & REGULATIONS
(CONDENSED)ADMINISTRATIONI. PERSONNEL

A. The ABA Board of Directors, Officers and Committee Chairmen (See ABA Constitution, pages 6-9) are responsible for carrying out the policies and rules of the ABA and the IBF and reporting the results of votes on matters of general interest to ABA members through mailings to associations, independent clubs and groups, and individual members.

B. Each ABA Director is elected by vote of all members living within the Region to be represented by the elected Director. Directors for each region are apportioned on the basis of total membership in the Region as of June 30 the previous year.

C. The Officers (President, First Vice President, Second Vice President, Secretary and Treasurer) are elected by the Directors from their group. The Officers, with the addition of the Immediate Past President, make up the Executive Committee.

D. Chairmen of Constitutional and Special Committees who are appointed by the President with the approval of the Directors carry out their respective responsibilities and report annually to the membership.

E. An Administrative Secretary is hired by the Board of Directors upon recommendation of the President to maintain records, supplies, general correspondence, and reports to members and others and carry out general administrative responsibilities.

II. RULES, REGULATIONS, & POLICIES

A. Rules, regulations and policies which govern ABA activities include those found in:

1. International Badminton Federation (IBF) Rules & Regulations
2. ABA Constitution
3. ABA Articles of Incorporation
4. ABA Rules Book
5. ABA Handbook

B. Committees, the Board of Directors and ABA Officers follow the rules and regulations as listed in the above publications (and this condensed version of the Rules and Regulations) in their efforts to work for the promotion of badminton in the USA.

III. OFFICIAL PUBLICATIONS

A. ABA BULLETINS are published from time to time by the

Executive Committee of the ABA and are distributed to every player in member associations and clubs and individual members of the ABA. It contains working information of primary interest to ABA members.

B. ABA HANDBOOK, first published in 1952 as a loose leaf book, contains all of the official rules and regulations of the ABA as well as historical facts of interest as to winners of competition and awards made each year. The Handbook is brought up to date each year by the issuance of "Insert Sheets" to take the place of those no longer current. The Handbook sells for \$2.00 with a charge of no less than 50¢ each year for the Insert Sheets. Handbooks and/or Insert Sheets may be ordered from the Administrative Secretary:

Mrs. Virginia B. Lyon
1330 Alexandria Drive
San Diego, CA 92107

C. BADMINTON USA is the Official Magazine publication of the ABA. It is published a minimum of four times a year and may be obtained for \$3.00 a year (\$3.25 in Canada and \$3.50 Overseas) from:

Mrs. Grace Devlin
RFD # 2 Dolfield Road
Owings Mills, MD 21117

D. The Official Rules Book is printed by the ABA. It contains the IBF Laws of Badminton, many valuable hints on playing, handling tournaments, and interpretations of laws.

1. Copies of the Rules Book may be secured for 25¢ each (25 to 99 copies, 15¢ per copy; 100 copies up, 10¢ per copy, all postpaid) from the Rules Book Chairman:

Lester Hilton
15 Tanglewood Drive
Cumberland, RI 02864

2. Royalties: The Rules and Regulations of the ABA may be printed and published only with the specific permission of the ABA, and, when distributed for profit, only upon payment of a specified royalty. (Contact Rules Book Chairman for details on Royalties.)

E. IBF Handbook is published each year in England. It may be obtained for 10 Shillings from the Honorary Secretary of the IBF:

Mr. HAE Scheele
4, Madeira Avenue
Bromley, Kent
England

This Handbook contains a statement of the names and addresses of all of the affiliated associations; the names of the officers of the IBF and the affiliates; the names of the title holders of all championship events of all nations from the inception of such events; and the results of all international matches. It also contains the regulations of the IBF with reference to:

International Badminton Championships: Thomas Cup
for men and Uber Cup for women
International Badminton Federation Organization

International Matches
National Tournaments
Professionalism
Laws of Badminton and Tournament Regulations

IV. MEMBERS

A. Applications for membership may be secured by writing to the Administrative Secretary, Mrs. Virginia B. Lyon. Samples of applications for association, club, or individual membership in the ABA appear in the appendix of this book. Dues for the 1968-1969 season are \$1.75 assessment per player in clubs (may be raised in any manner preferred by the clubs), \$5.00 for Individual memberships which includes a subscription to BADMINTON USA, and a \$100.00 Life Membership which also includes the BADMINTON USA subscription.

B. Reports to Members: The Administrative Secretary of the ABA sends information as to important items submitted to the Board to the president and secretary of each association and independent club member and individual member at the same time it is mailed to the Directors. This is for information to the members and guidance in making suggestions to the Directors of the ABA before a vote is taken on such matters. After the vote, a report of the action of the Directors on such matters is sent to the president and secretary of each association and independent club member and individual members.

V. ABA PINS - 3 Classes

A. The Official ABA Pin is to be given to each Thomas Cup and Uber Cup team member picked to represent the USA, the team coach, and the ABA President. Only one pin will be given to any one individual.

B. A "Give Away Pin" is to be given in quantity, as determined by the Executive Committee, to players who take part in any International Matches.

C. The third class of pin is one that any member of the ABA may buy for himself to wear or give away as gifts. These pins and the price list may be obtained by writing to the Administrative Secretary.

AMATEUR STANDING RULES *

- I. DEFINITION: Any badminton player is an amateur who:
- A. Does not receive, or has not received within 12 months since requesting reinstatement as permitted in sub-paragraph 2. hereof, below, directly or indirectly, pecuniary advantage by the playing of the game. In this connection, the phrase "playing of the game" shall not be construed as including the activity, whether playing or otherwise, exerted in the course of making or having made films for instructional or educational purposes, nor shall it be construed as including teaching, coaching, or demonstrating the game as a physical education instructor or professor or recreation director at a school, college, university, or recreation department or facility--all of which categories envisioned in this sentence shall be permitted activities.
 - B. Having lost his amateur status under 1. has been reinstated by the Amateur Status Committee of the ABA.
- II. EXPENSES: It shall be permissible to accept money for expenses in, or traveling to and from a sanctioned tournament or exhibition of the ABA if receipt of said funds is not in violation of the rules of the IBF.
- III. PROHIBITED ACTIVITIES: A player will have been considered to have forfeited his amateur status if he engages in the following acts:
- A. Enters a competition open only to professionals;
 - B. Plays for a money prize or gate receipts;
 - C. Plays in a tournament, team or exhibition match where professionals play or where gate receipts are charged, unless permission to hold such match has been obtained in advance from the National Tournament Committee or from an association member under the jurisdiction of which such event is to take place.
- IV. REINSTATEMENT: Upon forfeiture of amateur status, any player may request the Amateur Status Committee for reinstatement and the Committee, upon evidence satisfactory to it, may so reinstate the player after a twelve month waiting period.
- V. INTERPRETATION: Any construction made by the Amateur Status Committee of the ABA as to the meaning, effect or application of any of the rules of amateur standing shall be binding upon all concerned, subject only to appeal under Section 5 of Article VIII of the Constitution of the ABA.

* Adopted 10/6/68 by the ABA Board of Directors, subject to IBF approval.

APPEAL TO THE EXECUTIVE COMMITTEE OR BOARD OF DIRECTORS

1. The procedure to be followed Any ABA member desiring to appeal under Article VIII, Section 5 of the Constitution shall notify the Administrative Secretary of the ABA and accompany the notice with a statement of the facts involved, together with such supporting data and statements of reasons as he desires to submit.
2. A copy of such statements and reasons shall, as soon as possible, be sent air mail by the Administrative Secretary to:
 - a. Each member of the body to which the appeal is taken;
 - b. Each member of the Committee whose decision is appealed from;
 - c. The other party, or parties to be affected by the decision.
3. The members of the committee whose decision is appealed from and the other party affected by such decision shall have ten days from the date of such mailing by the Administrative Secretary in which to file with the Administrative Secretary such answer as it is desired to submit in response to the statements referred to in paragraph 1.
4. Upon receipt of such answering material, the Administrative Secretary shall send a copy thereof to:
 - a. The member body which has taken the appeal;
 - b. Each member of the body to which the appeal is taken.
5. The member appealing shall have ten days from the date of such mailing of the answering material by the Administrative Secretary in which to file with the Administrative Secretary matter strictly in reply to that set up in the answer.
6. The Administrative Secretary shall, as soon as possible after receipt of such reply material, forward the same by Air Mail to the same persons mentioned in paragraph 2.
7. The matter shall thereupon be deemed to be submitted to the appeal body for decision.
8. The votes of the appeal body shall be mailed to the Administrative Secretary.
9. The decision of the majority of the appeal body shall be conclusive. In case of a tie vote, the decision of the committee shall be affirmed.
10. Each party submitting materials to be forwarded by the Administrative Secretary, as above set forth, is required to supply the same in sufficient number to send one copy to each of the respective parties entitled to receive the same as set out above.

AWARDS

Emblems, pins and trophies are awarded by the ABA to champions, persons who have given outstanding service to the ABA as players or administrators.

I. ABA EMBLEMS

A. The Official Emblem of the ABA is that which appears on the cover of this book.

B. The Administrative Secretary is authorized to distribute emblems, with the appropriate designations as noted below, to those who are entitled to receive them.

1. USA NATIONAL CHAMPIONS

a. Emblems will be awarded to all USA champions for each officially approved USA National Open Tournament event won. An individual player will be awarded an emblem only for an initial championship in each event. Players who win in a subsequent championship, an event for which they have previously received an emblem, may, if they so desire, receive another emblem for that event by requesting it from the Administrative Secretary.

b. USA Closed Championships emblems will be awarded for each event won to all closed championship winners when such championships are held. An individual player will be awarded an emblem only for an initial championship in an event. Players who win a subsequent championship in an event for which they have previously received an emblem, may, if they so desire, receive another emblem for that event by requesting it from the Administrative Secretary.

c. The embroidered designations on these emblems shall include the word "Champion" and immediately below, that of the appropriate event designation as follows:

Ladies' Singles
Men's Singles
Ladies' Doubles
Men's Doubles
Mixed Doubles
Senior Doubles (for
both men and women
and mixed)

2. USA NATIONAL JUNIOR CHAMPIONS

a. Emblems will be awarded to champions of each age class (18 and under, 15 and under, 13 and under) irrespective of the event won. A player will be awarded one emblem for winning one or more events in a particular age class regardless of the number of times he wins that event or events in the same age class in subsequent years.

b. The embroidered designations on these emblems shall include the word "Champion" and immediately below that, the word "Junior".

c. Any player winning or participating with another player in winning an official annual Junior Championships event will thereafter be entitled to wear the ABA Junior Champion emblem.

3. THOMAS CUP & UBER CUP --- The official emblems for members of the Thomas Cup or Uber Cup teams shall be "THOMAS CUP" or "UBER CUP".

4. OTHERS -- The President and the Secretary of the ABA are entitled to wear an ABA emblem upon taking office. The emblem shall be embroidered with the titles of "PRESIDENT" or "SECRETARY".

II. ABA PINS

Official ABA Pins are given only to the ABA President, the coach and members of the Thomas Cup and Uber Cup squads picked to represent the USA. Only one pin will be given to any one individual. (See page 13 for other ABA pins)

III. ABA TROPHIES

A. Perpetual Trophies of the National Junior Championships and Open Amateur Championships of the ABA.

1. The Executive Committee of the ABA shall constitute a Board of Trustees for the National Junior and USA Open Championships perpetual trophies with power, subject to these rules and regulations, to make such arrangements and take such action as the Trustees may, from time to time, determine upon in connection with the continued safety of such perpetual trophies and all matters relating thereto.

2. Trophies shall be for annual competition in the events for which trophies shall have been given in the National Junior and US Open Amateur Championships as arranged by the ABA. Competition for such trophies shall be restricted to fully qualified juniors and amateurs as, from time to time, prescribed by the ABA rules.

3. Trophies shall be of sterling silver and of such design as shall have been approved in each case by the Trustees. The Trustees shall have full authority to accept or reject, on any grounds they may determine, any offer made of a trophy or trophies for the National Junior or Open Amateur Championships.

B. Responsibility for Perpetual Trophies

1. The winner of the trophy shall be responsible for the safekeeping of the trophy.

If a junior winner is not a member of the ABA, then a parent who is a member of the ABA through an association, club, or as an individual member or some other player who is an ABA member may sponsor in writing the junior winner.

2. The winner of each trophy, or the party responsible in the case of juniors, shall, promptly after the close of the Championships at which the trophy has been presented, provide the Administrative Secretary of the ABA with a formal receipt for the trophy. (See "Acknowledgment Form", Appendix)

3. The name of the winner(s) and the year shall be engraved in the proper place and in full conformity with the established design and the bill for the engraving submitted to the ABA. Payment by the ABA for the engraving will be based upon a reasonable rate as determined by the Executive Committee through comparative bids.

4. The winner(s) of the trophy shall be permitted either to personally transport the trophy to his or her home (provided such trophy is not taken outside the continental limits of the United States), or to have the trophy forwarded to such destination without expense to the ABA. However, at the election of such winner(s), such trophy may be left in the custody of the ABA without further responsibility or connection therewith on the part of such winner(s) or sponsor(s).

5. Party responsible for each trophy shall deliver the trophy in its shipping case, or cause it to be delivered, prepaid air freight, at least one month in advance of the succeeding Championships. Upon receipt of the shipping bill by the ABA Administrative Secretary, the sender will be reimbursed.

C. In the event that no National Junior Championships or USA Open Amateur Championships is held within 13 months after the close of the preceeding Championships at which the trophy was presented, the party responsible for each trophy shall deliver it to the ABA Administrative Secretary promptly after the expiration of 13 months in accordance with 2.e. above.

D. Engraving: Official wording for all trophies awarded at National Championships shall be:

1. Juniors -- "AMERICAN BADMINTON ASSOCIATION NATIONAL JUNIOR CHAMPIONSHIPS"

2. Open Amateur -- "OPEN AMATEUR CHAMPIONSHIPS OF THE AMERICAN BADMINTON ASSOCIATION"

IV. SPECIAL AWARDS

A. Davidson, Ken: Memorial Awards

In honor of Kenneth R. Davidson, the ABA in 1955 initiated the Annual Ken Davidson Memorial Award. It is

awarded to one junior and one adult* player in this country who is adjudged to have contributed the most to badminton, and whose sportsmanship, attitude, and achievement best exemplify the spirit of badminton held in such high esteem by Ken Davidson, himself.

1. Rules for selecting the winners of the Ken Davidson Memorial Trophies:

a. The Kenneth R. Davidson Junior and Adult* Memorial Trophies shall be awarded annually, in accordance with these rules, at the Junior and Open Amateur National Championships, respectively, by the appropriate Selection Committee, to the player in each Championships who is determined to have made the greatest contribution to the game of badminton, through his or her sportsmanship, or in other ways, either during such Championships, or otherwise.

b. Appointment of the Committees: With respect to each of the National Championships, at, or prior to the time thereof, the President (or such person as shall have been designated by him to make the appointment) shall appoint a Selection Committee composed of persons in attendance at such Championships (two of whom shall be players entered in such Championships). The Chairman of such committee shall be the President of the ABA if in attendance, otherwise, the Chairman shall be such person in attendance as shall have been appointed by the President (or shall have been appointed by the person designated by the President as aforesaid to make the appointment). The Committee shall have, in addition to the Chairman, four other members with wide acquaintance with the players, and, so far as practicable, from different sections of the United States.

2. Eligibility

a. No person shall be eligible for selection unless he or she shall be a bona fide contestant in the Championships at which the selection is to be made.

b. In the case of each trophy, any person who has previously been awarded such trophy shall thereafter be ineligible for such trophy.

3. Nominations

a. The Committee shall, at some appropriate time during the course of the Championships, announce that nominations are in order and shall designate the form which such nominations shall take and the method by which they shall be communicated to the Committee.

 * The Word "Adult" is used throughout this book replacing the word "Senior", now used to designate former "Veteran" events.

Such announcement shall also include a general statement of the factors to be considered by the Committee in determining the winner.

b. In the event that the Committee deems it advisable to poll the contestants, such poll shall be taken by written ballot and all contestants mentioned in such balloting shall be nominees. In the event a ballot is used, it is suggested that it be substantially in the following form:

BALLOTKENNETH R. DAVIDSON MEMORIAL TROPHY

The trophy is awarded annually to the player in these Championships who is determined to have made the greatest contribution to the game of badminton, through his or her sportsmanship or in other ways, either during these Championships or otherwise.

The Selection Committee, which is charged by the ABA with making the award, asks that every contestant assist them in making the selection. While the results of this balloting are in no way binding upon the Committee, your ballot will be given considerable weight by the Committee in reaching its decision.

TO THE COMMITTEE: I wish to nominate _____

as the person best qualified for the Kenneth R. Davidson Memorial Trophy for the year _____.

Please return this ballot prior to the start of the semi-finals.

c. At the discretion of the Committee, nominations may be made, not only by contestants, but by any person actually in attendance at the Championships, and the Committee may nominate additional contestants at its own discretion.

4. Time of Selection and Award: Selection shall not be made prior to the semi-finals of the Championships, but shall be made prior to the finals and the selection shall be announced and the award made at an appropriate time during the course of, or immediately following the final matches.

(Note: A small trophy that may be kept by the winner is provided by the ABA each year from a special Ken Davidson Trophy fund.)

B. Helms Hall of Fame Plaque

1. The purpose of this award is to honor an individual for achievement in the sport of badminton. Measures of achievement are generally considered as: excellence in play, sportsmanship, helpfulness to others, and cooperation.

2. The Helms Hall of Fame is a private enterprise in Los Angeles, California, honoring outstanding athletes in many fields. The actual award is made by the Directors of the Helms Hall of Fame Foundation. The ABA merely selects a candidate for the Helms Foundation approval.

3. Recommended Selection Procedure: The following rules will not be binding upon the Selection Committee, but are to be used as a guide in their selection of a nominee each year.

a. Eligibility shall be limited to past and present USA National Champions in any event, or members of the USA Thomas Cup or Uber Cup Teams. (In case of close decisions only, contribution to the game may be considered as a determining factor, but playing ability, ordinarily, will be the primary factor in all selections.)

Only in cases of truly outstanding administrative contribution to the game, and at the discretion of the Helms Hall of Fame Selection Committee, a person may be nominated who does not qualify in the general eligibility of excellence of play as described above.

b. Recipients of the award must be citizens of the USA or have been a permanent resident at the time they qualify under paragraph a. above.

c. Insofar as is possible, the Committee shall consist of five former recipients of the Helms Hall of Fame award, including the Chairman, and be geographically distributed as to represent all major areas of the USA.

d. Selection shall be made by a majority of the five votes and the selection need not be unanimous.

e. No more than one selection shall be made in any one year except under unusual circumstances.

4. Reporting the Committee's selection: The final selection of the Committee shall be mailed to the ABA President, who shall forward the selection to the Executive Committee for concurrence. Upon receipt of concurrence from the President, the Selection Committee Chairman shall submit the selection to the Board of Directors of the Helms Hall of Fame Foundation. The selection shall be held in strictest confidence at all times by the members of the Selection Committee and the Executive Committee. Agreement is necessary before the submission to the Helms Board of Directors. Such agreement shall be carried out before the Annual Meeting of the ABA.

C. Players' Appreciation Award -- Established in 1966 Each year, by vote of a players' committee, a silver cup is awarded to someone they feel, as a non-tournament player, has done the most for badminton.

INTERNATIONAL BADMINTON

- I. The ABA, along with some 58 other national associations, make up the membership of the International Badminton Federation (IBF) with headquarters in London, England. It is through meetings with representatives of these national associations that the Laws of Badminton for national and international play are established.

The rules listed here are some of those of primary interest to players and groups planning any international competition. For more details all of the Laws may be found in the IBF Handbook (See page 12).

II. NATIONAL OPEN CHAMPIONSHIPS

A. Any tournament of the status of a national open amateur championship (i.e., not restricted to the players of the country concerned) shall be subject to the following regulations:--

1. The Tournament must be under the direct control of the national organization of the country in which it is held.
2. Only one such tournament may be held annually in any country.
3. The title and dates of the Tournament must be sanctioned by the Tournament Committee of the IBF, and every application shall be made in writing to conform to the following requirements:
 - a. for a tournament desired to be held between October 1 and April 30, application must be made by the preceding May 31.
 - b. for a tournament desired to be held between May 1 and September 30, application must be made by the preceding September 30.
4. Two or more tournaments in the same continent shall not be sanctioned for the same date without the special consent of the Council of the IBF.
5. No player shall be eligible to compete unless he or she is a bona fide amateur, and is a member of a club affiliated to an organization in membership with the IBF. (Individual ABA membership is acceptable in this case.)
6. International specification for the court
 - a. The height of a court for international competitive play shall be a minimum of 26 feet or 8 meters from the floor over the full court. This height shall be entirely free of girders and other obstructions over the area of the court.

b. There shall also be at least four (4) feet or 1.25 meters clear space surrounding all the outer lines of the court, this space being also a minimum requirement between any two courts marked out side by side.

7. Shuttles

a. Modified shuttles, as permitted under Law 4, shall not be used without the consent of the organizations concerned.

b. One brand of shuttle only must be adopted for exclusive use during the Tournament, and the name of this brand must be advertised in the prospectus.

c. No rationing of shuttles per match must be allowed and all shuttles used must be a charge against the Tournament and not a charge against the players concerned.

B. Invitations to Foreign Players: Any tournament or exhibition match, to which it is desired to invite players from another country to compete, shall be subject to the following regulations:

1. The national organization of the promoting authority shall notify the national organization of the club to which the player shall belong when issuing the invitation

2. No player shall participate in any tournament or exhibition match promoted or organized by any individual or business house interested in the manufacture or sale of badminton equipment. Violation of this regulation shall result in immediate suspension of amateur status.

3. For the purpose of these regulations, a player's national organization shall be that to which the club, of which he or she shall have been an active playing member for the three months immediately preceding, shall be affiliated, and in the country in which he or she shall for the time being, be resident, and this shall be quite irrespective of the player's qualifications for international matches. (ABA accepts Individual ABA membership in lieu of club membership.)

C. Qualifications for International Players

1. ABA Thomas and Uber Cup Committees are instructed, when selecting a team to represent the USA in competition for the respective Cups, to take into consideration as an important factor, whether the respective players have been entrants in the National Open Championships of the ABA held prior to the time of selection, without, however, hereby making participation in such a national championships an absolutely inflexible requisite condition precedent for selection regardless of all other circumstances.

2. A player shall be qualified to represent a nation provided that he or she shall have:

a. for the three months immediately prededing the date of the fixture concerned, been a bona fide member of the association affiliated directly or indirectly to the IBF;

b. been born in, be a citizen of, or become a naturalized citizen of the country concerned, or shall have resided therein for two years immediately preceding the fixture concerned. Any question as to the interpretation or operation of this regulation shall be determined by the Executive Committee of the IBF whose decision shall be final.

3. When once a player has represented a nation, he or she will, subject to regulation 2 a above, always be eligible to represent that nation and no other, except that, always subject to 2 a above:

a. If two years shall have elapsed since a player last represented a nation, he or she will be eligible to represent any other nation for which he or she might then be qualified;

b. In the case of a woman, she shall upon marriage, be eligible immediately thereafter to represent the nation of which she may thereby accept citizenship; and likewise, on dissolution of such marriage by death or otherwise, she may immediately revert to her last previous qualification, provided that she may not represent more than one nation in the same season.

4. A player shall be deemed to have represented a nation if he or she shall have been officially nominated to represent that nation and shall have accepted such nomination.

5. If a player shall have represented a nation and such nation is subsequently divided into two or more nations or is absorbed by another nation, either politically or by recognition of the IBF, such player shall, for the purpose of these regulations, be deemed, from the date of such alteration, not to have represented any nation.

D. National Open Championships Draw and Seeding -- The ABA has adopted the recommendations of the IBF for all sanctioned ABA tournaments. Rules regarding the Draw and Seed are to be found under the chapter on Tournaments and Exhibitions.

III. LAWS OF BADI INTUN (PLAY) -- See the ABA Rules Book, enclosed.

JUNIOR ACTIVITIES

- I. All JUNIOR ACTIVITIES are under the guidance of the ABA Junior Activities Committee. The ABA President, after receiving recommendations from member associations, shall appoint, with the approval of the Board of Directors, one member from each Member Association as members of the Junior Activities Committee. Recommendations of associations shall not be binding on the President.
- II. JUNIOR AWARDS
 - A. ABA Emblems are awarded to winners in the National Junior Championships. (See AWARDS, pages 16 and 17)
 - B. Perpetual Trophies are awarded to the winners of the National Junior Championships. (See AWARDS, pages 17 and 18)
 - C. Each year an outstanding Junior is selected for the Ken Davidson Memorial Award. (See AWARDS, 18-20)
- III. JUNIOR THOMAS AND UBER CUP TEAMS
 - A. To establish incentive for improving USA general standard of men and women's play, a National Junior Uber Cup Team and a National Junior Thomas Cup Team have been approved.
 - B. It shall be one of the duties of the Thomas Cup and Uber Cup Committees to obtain the names of juniors and girls and boys up to the age of 21 years, within the areas which shall be designated under their control, to find adult players willing to take charge of junior squads, and to help them to organize squad activity such as practices, coaching, matches, etc.
 - C. Membership in the Junior Cup Teams will be determined as follows:
 1. Eligibility qualifications will be the same as those for the Thomas Cup and Uber Cup Teams, as outlined in the IBF Handbook regulations, except that the players must be 21 years of age or under on April 30 of the season in which they are selected for the Team.
 2. The Junior Thomas Cup and Uber Cup Teams shall consist of six singles players and three doubles pairs. The selection of players may be such that some individuals may be selected for both singles and doubles. However, the maximum number selected for the team shall not exceed twelve girls and twelve boys.
 3. A girl or boy who has at any time been selected to play on the adult Cup Team will no longer be eligible for selection to the Junior Team.
 4. The members of the Junior Cup Teams are to be selected in the following manner:

a. Each association member is requested to organize a Junior squad for both boys and girls.

b. Inter-Regional Tournaments or Trials are to be held from which Junior Cup Teams are to be selected by the Thomas Cup and Uber Cup Committees and the Junior Activities Committee and approved by the ABA Executive Committee.

IV. NATIONAL JUNIOR CHAMPIONSHIPS

A. Entitling and Entry Cards

1. The official wording for all announcements of the Junior Championships, their entry forms, their prizes, and other related materials and promotion shall be as follows:

"AMERICAN BADMINTON ASSOCIATION
NATIONAL JUNIOR CHAMPIONSHIPS"

2. National Junior Championships Entry Card: The following statement shall be printed on each individual entry card, or form of the National Junior Championships.

"According to the Rules and Regulations of the ABA, of which I am a member or sponsored by ABA
Member, I am an amateur in good standing and am qualified to entry in this tournament.

(Signed by) _____ Entrant."

B. Time and Sponsors of National Junior Championships

1. The Annual Junior Championships shall be held in the spring of each year at such place and upon such dates as may be approved by the Executive Committee.

2. Applications from association or club members in good standing, desiring the allocation of the National Junior Championships tournament, should be filed in writing with the ABA President at least 60 days prior to the annual meeting next preceding the tournament desired.

C. Player Eligibility

1. Competition shall be restricted to amateurs in good standing, provided they have received their parent's or guardian's consent and have established their residence within the USA for one continuous year.

2. Competition shall be restricted to amateurs who are citizens of the USA or aliens having established their residence within the USA for one continuous year preceding the Championships Tournament.

3. Competition shall be restricted to the following three official classes:

a. 18 years and under: Competitors in this class

shall be restricted to those who will not reach, or have not reached their 19th birthdays before April 30 of the year of the Championships.

b. 15 years and under: Competitors in this class shall be restricted to those who will not reach, or have not reached their 16th birthdays before April 30 of the year of the Championships.

c. 13 years and under: Competitors in this class shall be restricted to those who will not reach, or have not reached their 14th birthdays before April 30 of the year of the Championships.

D. Events and Scheduling

1. The following official events for all classes shall be included in the National Junior Championships:

Girls' Singles, Boys' Singles, Girls' Doubles
Boys' Doubles and Mixed Doubles

2. Subject to the approval of the Executive Committee, the organization holding the National Junior Championships may eliminate any event.

3. The ABA Match Scheduling system of play (see Tournament and Exhibition Chapter) shall be used in conducting the Annual National Junior Championships.

E. Financial Responsibilities

1. Any surplus resulting from the operation of the Annual National Junior Championships shall be divided 25% to the Club operating the tournament, 50% to the ABA and 25% to the Association sponsoring the tournament.

2. In the event that an association should, of itself, operate a tournament, its participation in the surplus shall be 50%.

3. The ABA share of the surplus shall be allocated for the development of Junior Activities by the Junior Activities Committee, subject to the approval of the ABA Executive Committee.

V. OTHER JUNIOR TOURNAMENTS

A. Sanctions: The policy of the ABA covering sanctions of tournaments and championships applies to all junior tournaments and championships. In the sanctioning of junior tournaments and championships, the same procedure shall be followed as in the case of adult tournaments and championships. (See Sanctions in chapter on Tournaments and Exhibitions)

B. Player Eligibility

1. It is the recommendation of the ABA that the age limits which apply to the National Junior Championships

be followed in all junior tournaments and championships.

2. Players under 16 years of age must have the approval of the Junior Activities Committee and the Executive Committee of the ABA to take part in the National Open Amateur Championships.

C. Results: Results of Junior tournaments and tournaments in which juniors participate shall be sent to the Chairman of the ABA Junior Activities Committee to be included in the file of materials to be used as a basis for junior rankings.

VI. RANKING

A. The Junior Activities Committee shall establish junior rankings and maintain such records and files with sufficient data to properly establish accurate ranking of all junior players by the ABA.

B. The general procedure of ranking as contained in these regulations (See-Rankings, pages 28 and 29) for USA rankings of adults, will be followed by the ABA Junior Activities Committee in preparing the Junior Ranking Lists.

C. The ranking lists thus determined, with necessary notes and explanatory materials to properly support the ranking lists submitted, shall be forwarded to the ABA President not later than 90 days after completion of the National Junior Championships. The ABA President and Executive Committee, after review of the lists shall, if they so desire, approve the ranking lists.

D. Conditions to be considered in establishing Junior Ranking

1. The official tournament season of the ABA during which results will be considered for ranking shall be May 1 through April 30.

2. Juniors having played in at least two sanctioned tournaments (Junior when possible, but in areas where there are not Junior Tournaments, then in adult tournaments), or have competed in the National Junior Championships of the current season.

3. Ten players or teams shall be ranked in the three age categories (See- Junior Activities C.3., pages 25-26) ONLY when there are sufficient statistics to substantiate such rankings.

RANKING

I. ADMINISTRATIVE PROCEDURE

- A. The official tournament season of the ABA during which results will be considered for ranking shall be May 1 through April 30.
- B. It shall be the responsibility of the Ranking Committee Chairman to collect the official tournament results from all sanctioned tournaments. Results of Junior tournaments and tournaments in which Juniors played an active part shall be sent to the Junior Activities Chairman. When either chairman is unable to get tournament results, the regional tournament chairmen shall be contacted. If the regional tournament chairmen fail, a request for obtaining the results shall be made to the directors of the Region in which the tournament took place.
- C. The Chairman shall:
1. Keep all members of the Ranking Committee informed on all ranking rules and the procedures to be followed;
 2. Act as a clearing house for transmission of all opinions;
 3. Prepare and submit to the Ranking Committee the record of each player and team to be considered;
 4. If, after one round of Ranking Committee voting, the resulting ranking lists submitted do not reflect a majority vote for each ranking in a particular event, or events, the Chairman shall, at his discretion, and in order to speed up the work, forward his proposed ranking list to the Ranking Committee members. This list shall not carry a vote, or be considered in any way binding on the Committee;
 5. The Chairman shall break any tie vote which may occur after at least two rounds of voting by the Ranking Committee; A majority vote will then determine the ranking.

II. RANKING LISTS

- A. Junior Rankings: See Junior Activities, page 27.
- B. Ten players or teams, who are citizens or permanent residents of the USA, shall be ranked in the following categories ONLY when there are sufficient statistics to substantiate such rankings:
- | | | |
|------------------------|-----------------|----------------------|
| Men's Singles | Men's Doubles | Mixed Doubles |
| Ladies' Singles | Ladies' Doubles | Senior Mixed Doubles |
| Senior Ladies' Doubles | | Senior Men's Doubles |

The Committee shall add a footnote, or a secondary list, to the regular ranking list which will set out the relative ranking of foreign players who have played in

the USA during the current season, but who are not eligible for ABA ranking,

C. Players and teams who fail to make the Ranking List may be alphabetically listed under:

1. Honorable Mention: This will be given to not more than four players or teams in each category who qualify for consideration.

2. Insufficient Data: This will be given to those players or teams in each category who qualify for consideration.

III. ELIGIBILITY

A. Junior Eligibility: See Junior Activities, page 27.

B. In order to qualify for consideration for a National Ranking a player or team must:

1. Be a citizen or a permanent resident of the USA on May 1 of the current season, and it shall be the duty of the Chairman to satisfy himself on this if necessary;

(A permanent resident shall be a player who has been a resident for two years prior to May 1 of the season in which he (she) is considered for ranking. Also excluded from ranking consideration shall be persons in this country as students or who reside in the USA on a temporary basis with the intent of returning to their native country.)

2. Have played in at least three sanctioned tournaments between May 1 of one year and April 30 of the following year;

3. Have reached the semi-finals of the National Championships to be considered for a "once only appearance" for a ranking over an established player or team.

C. Only matches which played at best two out of three games shall be considered, and tryouts, games of 21 points and round robin results shall not be considered. Scores from any foreign tournaments in which ABA members met each other or mutual opponents may be used.

D. In general, scores of the National Championships are to be considered the most important, and late season scores are to be given more weight than those in the early part of the season.

E. A player may be ranked with more than one partner provided each team meets the necessary qualifications.

IV. COMMITTEE RESPONSIBILITY

A. It is the obligation of the Committee members to consider themselves as representatives of the ABA, a national organization, and not the guardians or advocates of players in a particular region.

B. Votes of the Committee shall be on an analysis of tournament results and scores, and NOT a matter of opinion of relative play. Only when no direct wins or losses between two players or teams are available, shall scores against common opponents be considered.

* * * * *

1968 - 1969 NATIONAL RANKINGS
(Based on 1967-1968 Tournaments)

MEN'S SINGLES

1.	J. Poole	Louisiana
2.	R. Starkey	California
3.	S. Hales	California
4.	D. Paup	Louisiana
5.	T. Carmichael	Michigan
6.	T. Moehlmann	Missouri
7.	T. Heden	New York
8.	B. Berry	California
9.	R. Lyon	California
10.	R. Mitchell	California
HM	D. Ball	Massachusetts
HM	B. Gerzine	California
HM	M. Walker	California

LADIES' SINGLES

1.	T. Barinaga	Arizona
2.	D. O'Neil	Connecticut
3.	J. White	Michigan
4.	C. Root	Pennsylvania
5.	D. Hales	California
6.	C. Starkey	California
7.	P. Stockton	Michigan
8.	G. Page	California
9.	C. Kelly	Massachusetts
10.	R. McGuire	Connecticut

MEN'S DOUBLES

1.	D. Paup-J. Poole	LA
2.	J. Alston-W. Rogers	CA
3.	S. Hales-L. Saben	CA
4.	T. Moehlmann-J. McQuie	MO
5.	B. Anderson-B. Bedford	MI
6.	M. Hartgrove-W. Judy	CA
7.	T. Carmichael-J. Stevens	MI
8.	T. Heden-P. Lemon	NY
9.	F. Nelson-Wilson	NH
10.	J. Cooper-W. Goodman	RI-MA

LADIES' DOUBLES

1.	T. Barinaga-H. Tibbetts	AZ-CA
2.	L. Alston-D. Haase	CA
3.	J. Gray-C. Starkey	CA
4.	M. Breckell-J. Pons	CA
5.	B. Armendariz-D. Hales	CA
6.	C. Kelly-R. Lemon	MA-NY
7.	R. McGuire-D. O'Neil	CT
8.	P. Stockton-P. Stockton	MI
9.	G. MacFarland-A. Rutledge	CT-NJ
10.	L. Hurt-G. Page	CA

MIXED DOUBLES

1.	L. Saben-C. Starkey	CA
2.	J. Poole-T. Barinaga	LA-AZ
3.	J. Alston-L. Alston	CA
4.	D. Paup-H. Tibbetts	LA-CA
5.	T. Carmichael-D. O'Neil	MI-CT
6.	S. Hales-D. Hales	CA
7.	W. Johnson-V. Anderson	WA
8.	T. Carmichael-D. Bedford	MI
9.	T. Heden-C. Kelly	NY-MA
9.	P. Lemon-R. Lemon	NY
HM.	M. & B. Armendariz	CA
HM.	M. Armendariz-M. Breckell	CA

SENIOR MIXED DOUBLES

1.	W. Rogers-H. Tibbetts	CA
2.	B. Traquair-E. Marshall	NY
3.	L. Calvert-J. Pons	CA
4.	R. Majia-J. Pons	CA
5.	C. Randolph-L. Carlson	CA

SENIOR LADIES' DOUBLES

1.	E. Marshall-B. Massman	NY
2.	J. Pons-H. Tibbetts	CA

SENIOR MEN'S DOUBLES

1.	W. Lyon-W. Rogers	CA
2.	H. Clark-D. Kamperman	TX
3.	W. Anderson-B. Traquair	MI-NY
4.	L. Calvert-D. Trader	CA
5.	J. Cogan-C. Randolph	CA
6.	R. Mullen-J. Wigglesworth	IL
7.	H. Eissler-H. Miller	PA
8.	E. Phillips-H. Seavey	RI-MA
9.	J. Cornell-J. Vaniver	PA

18 & Under

15 & Under

13 & Under

Boys' Singles

1. Mike Walker	CA	1. Mark Rath	MI	1. Mike Czarnecki	MI
2. Mike Adams	MI	2. Charles Coakley	CA	2. Joel Rath	MI
3. Doug Bender	DE	3. Bruce Pontow	IL	3. Pat Trapnell	MI
4. R. McKinley	NY	4. Ron Buck, Jr.	IL	4. John Irwin	DE
5. Robert Jones	WA	5. Norm Couture	CA	5. John Sieck	MD
6. Dave Domzal	MI	6. Chris Coselman	MI	6. (Guy Rittman	RI
7. Gary Higgins	CA	7. Charles Fales	MI	(T. Munro	MA
8. M. Reichert	DE	8. B. Anderson	MD	8. B. Ekleberry	MI
9. Don Rittman	RI	9. Mark Murray	WA	9. Ruben Mejia, Jr.	CA
10. James Eden	WA	10. (Scott Enochs	CA	10. (Peter Cornell	PA
		(James Kohler	CT	(Pat Tryon	DE

Girls' Singles

1. Chris Burton	WA	1. Pam Stockton	MI	1. Susan Pritula	MI
2. Polly Stockton	MI	2. Sandra Muthig	MI	2. Mary Lynn Bell	MI
3. Alison Root	PA	3. Jo Ann Kennedy	MI	3. Susan Kane	DE
4. Nancy Bender	DE	4. Nancy Fedea	MI	4. Rose Harvey	MD
5. Ellen Van Os	WA	5. Diana Sands	WA	5. Leslie Schoppe	CA
6. Connie Young	WA	6. Diana Mies	CA	6. Jeanne Stelzer	CT
7. Wendy Zaharko	DE	7. Kay Roland	MI	7. B. Fromholz	MI
8. Kay McDonald	RI	8. Tracy White	CA	8. Lori Gerzine	CA
9. Hester Hill	WA	9. (Noreen Pringle	WA	9. Casey Janz	OR
10. Diane Sinnes	WA	(Mary Booth	WA	10. Terry Casady	CA
		(Lynette Buck	WA		

Boys' Doubles

1 Kinard-Walker	CA	1 Buck, Jr.-Pontow	IL	1 Rath-Trapnell	MI
2 Adams-McKinley	MI-NY	2 Couture-Fogarty	CA-MA	2 Irwin-Sieck	DE-MD
3 Cierich-Muntz	OR	3 Coakley-Rath	CA-MI	3 Czarnecki-Ekelberry	MI
4 Bender-Domzal	DE-MI	4 Murray-vanHorn	WA	4 Cornell-Tryon	PA-DE
5 Higgins-Jones	CA-WA	5 Kohler-Roberts	CT-PA	5 Rittman-Weintraub	
6 Eden-Peddrick	WA-DE	6 Coselman-Janz	MI-OR		RI-NY
7 Barr-Parker	MI			6 McManus-Munro	MA
8 McMahon-Rittman	NY-RI			7 Downing-Mejia	DE-CA
				8 Kelly-Steinbronner	CA

Girls' Doubles

1 Burton-Van Os	WA	1 Sands-Buck	WA	1 Pritula-Schoppe	MI-CA
2 Hill-Young	WA	2 Kennedy-Stockton	MI	2 Kane-Stelzer	DE-CT
3 Stockton-Stockton	MI	3 Schoppe-White	CA	3 Bell-Harvey	MI-MD
4 Bender-Root	DE-PA	4 Bell-Muthig	MI	4 Janz-Lundberg	OR
5 Fedea-Owens	MI	5 Barnhill-Mies	DE-CA		
6 Dunn-Sinnes	WA	6 Czarnecki-Roland	MI		
7 Trapnell-Wehunt	MI-CA				
8 Froelich-Zaharko	MD-DE				

Mixed Doubles

1 Walker-Burton	CA-WA	1 Pontow-Muthig	IL-MI	1 Trapnell-Gerzine	MI-CA
2 Bender-Van Os	DE-WA	2 Rath-Pritula	MI	2 Czarnecki-Fromholz	MI
3 Adams-Stockton	MI	3 Coakley-Mies	CA	3 van der Waal-Janz	OR
4 Higgins-Young	CA-WA	4 Couture-Gerzine	CA	4 Sieck-Harvey	MD
5 Cierich-Hill	OR-WA	5 Coselman-Kennedy	MI	5 Irwin-Kane	DE
6 Jones-Root	WA-PA	6 Murray-Buck	WA	6 Tryon-Lundberg	DE-OR
7 Domzal-Bender	MI-DE	7 Enochs-White	CA	7 Mejia-Stelzer	CA-CT
8 Muntz-Sinnes	OR-WA	8 Buck, Jr.-Cornell	IL	8 Downing-Peiffer	DE
9 Rittman-McDonald	RI	9 van Horn-Pringle	WA		PA
10 Eden-Zaharko	WA-DE	10 Fogarty-Fogarty	MA		

REFEREES, UMPIRES AND LINESMEN
RULES AND REGULATIONS

In order to have consistency in umpiring throughout the country, it is requested that these instructions be followed in all sanctioned tournaments.

Duties of the Referee

In the case of each tournament, those in charge shall appoint a Referee to act for them in regard to rules, scoring and similar factors of match play. The Referee:-

1. Shall be in complete charge of match play, except for the scheduling of matches (either as to time or place).
2. Shall be thoroughly familiar with the Official Laws of Badminton and the interpretations which are part of the rules.
3. Shall rigidly enforce all rules.
4. Shall have the power and responsibility to appoint and remove Umpires, Linesmen, and Service Court Judges.
5. Shall see that nets are at the correct height and that correct shuttles are used after testing for speed.
6. Shall be the final authority on appeal from the decision of the Umpire with power to reverse the Umpire's decision involving a point of law, only. The scoring of a match can be affected only if the appeal is made to the Referee before the next service is delivered.
7. Shall be present on or adjacent to the playing area at all times during the match play or be specifically represented by a deputy appointed by him.

Duties of the Umpire

The Umpire:-

1. Shall, upon taking the court, and before the players rally,
 - a. Arrange the toss for service or court.
 - b. Write upon the score card the starting position of the contestants, the name of the server and the receiver.
2. Shall be in complete charge of his match except for such higher authority as rests with the Referee.

Referees, Umpires and Linesmen (2)

3. Shall make all calls promptly and clearly, calling the score, lets, faults (unless these are specifically assigned to linesmen or service court judges, in which case he must await their call or signal) IBF Law 14 (h) as amended 1968 reads "It is a fault if the shuttles be held on the racket (i.e. caught or slung) during the execution of a stroke; or if the shuttle be hit twice in succession by the same player with two strokes; or if the shuttle be hit by a player and his partner successively."
4. Shall see that contestants do not leave the court after match has started unless granted permission. (Exception-Five minute interval allowed between second and third games in singles events and senior doubles but no player is to leave the general playing area during this interval.)
5. May allow a contestant to leave court for a period as he may consider necessary under circumstances not within the control of the player. The umpire shall be the sole judge of any suspension of play and he shall have the right to disqualify an offender.
6. Shall call service and receiving faults except if a Service Judge is assigned.
7. Shall insure that players serve and receive from the proper courts.
8. Shall insure that courts are changed in accordance with Law #8 of the Laws of Badminton.
9. Shall insure that the option of "setting" is properly exercised.
10. Shall uphold the decisions of Linesmen or Service Court Judges.
11. May remove a Linesman or Service Court Judge for good cause, subject to final decision of Referee.
12. May decide when Linesmen or Service Court Judge is unable to render a decision, himself, or may call a "let" and replay the point.
13. May call a "let" and replay the point if action of spectators interferes with the players.
14. Shall take the score to the Official Scorer at once at the conclusion of the match.
15. May order a point replayed where a Linesman or Service Court Judge corrects his decision if the call has affected the play of either side.

Duties of a Linesman

1. Shall watch his line carefully. An IN or Out decision is made on the floor contact of the cork and NOT the feathers of the shuttle. Thus a flat angled bird may be OUT although the feathers are well inside the court line. If the cork touches ANY PART of the line, it is "IN".
2. Shall call "OUT" promptly in a clear voice loud enough to be heard by the players and the spectators, and at the same time signal by extending both arms horizontally so that the Umpire can see clearly.
3. If the shuttle falls in say nothing. If unsighted, inform the Umpire immediately.
4. Shall never appeal to either PLAYERS or SPECTATORS.
5. Shall have the final decision on all points relative to his own line.
6. May correct his decision on a point but shall notify Umpire before next service is delivered.

Duties of a Service Court Judge

1. Shall watch and call the server for foot faults and service faults.
2. Shall watch and call the receiver for foot faults and illegal rushing of the service.
3. Shall watch the service line for a short service and call if receiver does not play.
4. Shall make a decision promptly unless unable to judge accurately. If his view is obstructed, shall immediately notify the Umpire.
5. May correct his decision but shall notify the Umpire before the next service is made.

NOTES

- (1) Each linesman and service court judge should be at his assigned position before the match starts and may not leave before the match ends without the consent of the Umpire.
- (2) The correct call when an infringement of the Laws has occurred is "Fault". When a doubt arises in the mind of the Umpire or service Judge as to whether a Fault has occurred or not, "Fault" should NOT be called and the game allowed to proceed.
- (3) Clear and audible calls are of great benefit to the players, spectators, and other officials.

SHUTTLECOCKS APPROVAL AND ADOPTION

The jurisdiction of the Shuttlecock Committee includes all matters pertaining to shuttlecocks necessary or advisable for the benefit of the ABA and the betterment of the game, so far as such jurisdiction is consistent with the Constitution and with our contract with LCA.

I. APPROVAL OF SHUTTLECOCKS FOR TOURNAMENT PLAY

A. The ABA will advise all member clubs and associations that they must use only shuttles approved by the Shuttlecock Committee for tournaments sanctioned by the ABA.

1. A definite plan of approval shall be followed.
2. Approval shall be given annually, to be announced not later than July 1 of each year. Approvals may also be given during the year to any concern submitting a request for the same.
3. Notification to shuttlecock manufacturers or distributors of the award or rejection of approval shall be made by the Administrative Secretary of the ABA after a full report from the Committee.
4. There shall be a charge of \$25.00 per brand to any concern, manufacturer or distributor, which submits shuttles for test. Round or pointed feathers under the same brand name shall be considered one brand for the purpose of this paragraph.
5. The Committee shall approve only "For Tournament Play."
6. Any concern may submit as many shuttles as it may desire, but only the single charge of \$25.00 will be made for one brand.
7. The Committee will approve or reject each shuttle by brand name, regardless of whether shuttles may be made by one manufacturer and submitted to it by one or more concerns.
8. No manufacturer or distributor is obliged to submit shuttles for testing and approval by this Committee.
9. Carlton Nylon Shuttles (Tournament grade) have been approved for use in all tournaments except Class A Championships and Open tournaments.
10. The grant of approval allows the concern to use the term: "APPROVED FOR TOURNAMENT PLAY BY THE
AMERICAN BADMINTON ASSOCIATION."
or similar wording, for any publicity it may desire during the term of approval.

11. Any manufacturer or distributor granted this approval must agree not to ship to retail outlets any shuttles with advertising showing ABA approval after the expiration of the term of approval without written permission of the Committee.

12. Approval of a shuttlecock submitted by a concern shall not be effective until such concern shall have signed and delivered to the Administrative Secretary of the ABA an agreement in the form attached to these rules and regulations. Violation of such agreement or any infraction of these rules and regulations will warrant the ABA in recommending the non-use of the shuttlecock in question by associations, clubs and individual members of the ABA.

B Form Of Agreement:

The undersigned (name of manufacturer or distributor), having read and understood the rules and regulations governing the approval and adoption of shuttlecocks by the ABA, hereby, on consideration of the approval of the undersigned's shuttlecock

_____ (Name of Shuttlecock) _____
by the Shuttlecock Committee of the ABA, accepts and agrees to the provisions of such rules and regulations now in effect, and also agrees with the ABA that the provisions of Rule 11 of said rules and regulations will be strictly complied with after the expiration of the term of such approval.

(Signed) _____ (Name of manufacturer or distributor)

BY _____ (Name of authorized person)

II. NATIONAL CHAMPIONSHIPS ADOPTION

A. After careful study of the question of rotation of the adoption, or open competitive bidding, the policy of open competitive bidding has been chosen.

B. The Committee shall give first consideration in its selection to those concerns who have been given approval. No shuttle rejected as suitable for "For Tournament Play" shall be considered in the selection.

C. The Committee shall issue call for bids no later than October 1, and its report of the selection shall be submitted to the President of the ABA not later than December 15

D. The award of the adoption shall be made so that the concern chosen will be notified not later than January 1 of the year the Championships is to be held. Notification shall be made by the Administrative Secretary of the ABA. She shall notify all associations and club members of the name and brand of the shuttle adopted for each National

Championship as soon as the report of the selection is made by the Shuttlecock Committee.

E. The Committee is permitted to request from all concerns bidding that they submit whatever number of shuttles the Committee desires, free of charge. This amount shall not exceed one dozen to each member of the Committee, unless extra tests are found necessary.

F. The terms of the bid and award shall include the following:

1. The price of the shuttles per dozen will be a fixed price decided upon by the Committee after consultation with the President and announced in the call for bids. As closely as possible, this figure should be that generally recognized by leading concerns as cost figures.

2. There shall be no guaranteed bird consumption.

3. A competent shuttle expert, representing the concern with all authority, should be in attendance at the National Championships and in charge of the shuttle supply while the tournament is in play.

4. The ABA, by duly authorized representatives, shall be permitted to examine and test for approved use all shuttles to be used.

5. The concern awarded the adoption shall pay a fee of \$50.00 for either the Open National or Junior Championships for the award and will be given the privilege of first call on a full page advertisement in the official programs at the going rate of such page. Acceptance or rejection of the full page advertisement must be made in writing to the Tournament Committee within ten (10) days after notification of the award.

6. This concern shall bear no other printing or publicity expense as concerns the ABA direct, but it may, at its own expense, be permitted to announce, circularize, or distribute posters regarding the event, using its own name on this material in any way it may desire.

TOURNAMENTS & EXHIBITIONS

I. CHAMPIONSHIPS: The use of the word "Championships" in the title of a tournament shall be limited to tournaments restricted to the following players:

A. Those residing in the territory embraced within the scope of the title;

B. Those who are members of a member club of an association or associations for such territory of an individual ABA region.

C. The Tournament Committee of an association or club may make any further restrictions as it may see fit.

II. EXHIBITIONS:

A. Matches in the United States:

1. No Admission Charges: Exhibition matches in the United States where there is no admission charge may be carried out at any time without authority, except for any association special ruling within its own jurisdiction, and amateurs may play with or against professionals without restriction, except that amateurs shall in no way receive money or the equivalent in excess of actual traveling and living expenses incurred.

2. Admission Charged:

a. Exhibition matches in the United States where there is an admission charge, may be authorized by the ABA Tournament Committee when submitted and approved by the Association Member in the region where the proposed match is to be held, provided that the proposed match is to be conducted under the auspices of the ABA association member, an affiliated club, or a recognized and reliable organization. Each authorization of an exhibition match shall be expressly conditioned upon the following:

1) The responsible organization shall, if requested by the Tournament Committee, present the Tournament Committee a statement showing all amounts in money or the equivalent paid directly or indirectly to each amateur participating in such exhibition.

2) No amateur in such exhibition shall receive, in money or the equivalent, in excess of his actual traveling and living expenses incurred.

b. All of the foregoing provisions shall apply where there is an admission charge, whether the

matches are between amateurs only, or between amateurs and professionals, or matches in which both amateurs and professionals take part in any other manner.

B. Matches in Foreign Countries: Any player or players affiliated with the ABA may take part in exhibition matches in other countries, provided, in the case of each such match, that no amateur participating therein shall receive in money or the equivalent in excess of his actual traveling and living expenses incurred, and that either--

1. such match shall have been duly approved by the governing body, or by authority duly delegated by that body, of the country where such match is held, or
2. the participation in such match by such player or players affiliated with the ABA shall have been approved by the ABA Amateur Status Committee.

III. NATIONAL CHAMPIONSHIPS (OPEN AMATEUR CHAMPIONSHIPS)

A. Entitling of National Championships (For National Junior Championships see page 25)

The official wording for all announcements of the Championships of the ABA and the entry forms, annual prizes, and other related material and promotion of such Championships shall be as follows:

"OPEN AMATEUR CHAMPIONSHIPS OF THE AMERICAN BADMINTON ASSOCIATION"

B. Entry Card: The following statement shall be printed on each entry card or form of the Open Amateur Championships of the ABA:

"According to the rules and regulations of the National Badminton Association of which I am a member, I am an amateur in good standing."

(Signed by) _____ Entrant.

C. Operation of Championships

1. The Open Amateur Championships of the ABA (hereinafter generally called "Championships") shall be held in the spring of each year, at such place as may be approved by the ABA Executive Committee, subject, when required, to the sanction of the IBF.

2. Open and Closed Championships at the Same Meeting: A sponsor of an Open Amateur Championships of the ABA is authorized, if it so desires, to conduct a closed amateur championships at the same time and place as the Open Championships are conducted.

3. No player shall be eligible to compete in the Championships unless:

- a) he or she is an amateur according to the rules

of the National Association, other than the ABA, with which the player's club is affiliated,

b) a member of a club in good standing affiliated with the ABA or with the IBF

c) an individual member of the ABA.

4. Limitation of the number of entries may be made only with the approval of the Board of Directors or the Executive Committee of the ABA, or pursuant to any rule or regulation hereafter adopted by said Board.

5. Applications for the operation of Championships must be filed in writing with the ABA President at least 60 days prior to the Annual Meeting next preceding the tournament desired. Such application may be made by an association member, a member club, or by any organization which is acceptable to the Executive Committee, provided always that any such application by an association affiliated club is sponsored by the association of which the club is a member.

6. The Championships shall include the following official events: Ladies' Singles, Men's Singles, Ladies' Doubles, Men's Doubles, Mixed Doubles, Senior Men's Doubles, Senior Ladies' Doubles, and Senior Mixed Doubles.

7. Subject to the approval of the Executive Committee, the organization holding the Championships may eliminate any event.

8. Age requirements;

a) Players under 16 years of age will not be eligible to compete in the Championships without special approval of the Junior Activities Committee and the Executive Committee.

b) The minimum age limit of each individual for the senior events is 40 years.

c) The foregoing age limitations are effective as of the first day of the Championships.

9. The ABA Match Scheduling System of play shall be used in conducting the Championships.

10. Regulations for awarding ABA Emblems and Perpetual Trophies (see pages 17-18)

11. "United States Player" as here used, means a player who is a member in good standing of the ABA and who, both at the time of the current Championships and at the time of such preceding Championships, is either a citizen of the United States or an alien who has established residence in the United States

for a period of at least six years immediately preceding such Championships.

12. To the extent that, as determined by the Executive Committee, the finances of the ABA are sufficient to permit the payment of traveling expenses, a U.S. player who competes in the current Championships shall be entitled to be reimbursed for his or her actual traveling expenses thereto, to the extent hereinafter stated, provided such player is:

a) competing in the current Championships in a singles event and was either:

1) the winner of such event at the preceding annual Championships (not Junior) of the ABA (whether such preceding annual Championships were annual championships or otherwise), or

2) the runner-up in such event at such preceding annual Championships, if the winner thereof was not a U.S. player, or

b) is competing in the current Championships in a doubles event (other than Senior events) as a member of the same team which competed in such event at such preceding annual Championships, and such team was either:

1) the winner of such event at such preceding annual Championships, or

2) the runner-up in such event at such preceding annual Championships if neither member of the winning team at the Championships had been a U.S. player.

c) If, as to any event in the current Championships, no U.S. player is entitled, according to the above rules, to be reimbursed for traveling expenses, none of the rules shall be deemed to prevent the Executive Committee from reimbursing any top ranked U.S. player or players competing in that event in the current Championships as the Executive Committee may determine upon, for all or part of his or her actual traveling expenses to the extent stated in the paragraph d. below.

d) Rules governing reimbursement of travel expenses:

1) The traveling expenses to which players are entitled to reimbursement shall be an amount not exceeding the round trip economy class air fare between the temporary or permanent place of residence of such player and the place where the current Championships are held.

2) Not less than 30 days before the Championships, the Administrative Secretary of the ABA shall notify each player who is to receive travel expense reimbursement of the approximate amount available to him or her.

3) Before payment each player shall submit to the Executive Committee a signed travel expense voucher for its approval and ratification.

13. Financial responsibility of the organization conducting the Championships:

a. Each association, club, or other organization operating a Championships shall pay to the ABA, as an expense of operating such Championships, the sum of \$600.00, or, in lieu thereof, such greater sum as the Executive Committee may designate, which last mentioned sum shall, however, not be in excess of the smaller of the following:

1) the total amount of the players' traveling expenses being reimbursed by the ABA in connection with such Championships, as provided above (d(1)) or

2) \$1,200.00

b. If the Championships are operated by any association or club member of the ABA, any surplus resulting from such operation shall be divided as follows:

1) 50% to the ABA, and

2) if an association, itself, or a club operates the Championships, 50% to such association or club, or

3) if the Championships are operated by a member club, 25% to such club and 25% to the association sponsoring the same.

c. Television Proceeds: Money obtained as the proceeds of the televising of the Championships of the ABA shall be allocated as follows, subject to the approval of the ABA Executive Committee:

1) One third to the ABA General Fund

2) Two thirds to the local tournament committee to be used to promote the stature of the Championships.

d. If the Championships are operated by any other organization, all financial arrangements between such organization and the ABA are to be determined by the Executive Committee.

IV. SANCTIONS

A. Policies

1. All tournaments conducted by association or club members of the ABA should be sanctioned. Sanctions are granted in order to insure adequate control over the tournaments.
2. While the sanctioning system was established in order to avoid conflicts, it does not necessarily follow that the ABA Sanction Committee can refuse to issue a sanction because of a conflict. The Sanction Committee is the clearing house for all tournaments and, while it lists the schedules and makes every effort to avoid conflicts, refusal to sanction is not entirely justified because of two or more tournaments being held on the same date. If, in spite of knowing of the conflicts, the groups desiring to hold the tournaments, wish to go ahead, it is not to the best interests of the game to deny the sanction.
3. No important tournament should be sanctioned in conflict with the National Junior or Open Amateur Championships.
4. State and regional tournament dates will be given protection within their respective areas.
5. Reasons for sanctioning tournaments other than to avoid conflicts of dates:
 - a. To insure that the tournaments will be run according to the ABA regulations.
 - b. So that players may be ranked.
 - c. To establish official champions in states and regions.
 - d. So that all play will be according to the rules and regulations of the ABA and the IBF.
 - e. To protect the amateur standing of all players.
 - f. In order that a record may be kept of the Tournament and official recognition given to the winners in the official publications of the ABA.
 - g. To control players' expenses and gate receipts.
6. While it is important for all tournaments to be sanctioned, it is possible for clubs to hold unsanctioned tournaments. However, these tournaments are not recognized by the ABA and they are not considered for official ranking. Clubs are cautioned to exercise due diligence with respect to all tournament contestants to be certain that there are no violations of the amateur regulations. Players participating in unsanctioned ABA tournaments may be

cited for violation of the amateur code in the case professionals participate.

7. Regional tournament sanction chairmen are permitted to recommend sanctioning of a tournament where it is sponsored by an ABA club or association member provided only that amateur players are entered who are residents within the scope of the tournament.

B. Regulations: Tournaments or exhibitions considered as requiring a sanction are those for which the ABA (Member) or the IBF charge an entry fee and/or admission.

1. Fees: For all tournaments and exhibitions held under the auspices of the ABA, an ABA sanction must be obtained and a fee paid therefor. No fee is required for Interscholastic or Intercollegiate tournaments.

a. The fee for all Open and "A" tournaments is \$5.00.

b. A \$2.00 fee is charged for:

1) All Junior tournaments;

2) All tournaments of a purely local character which are limited to contestants from clubs within a 25 mile radius of the tournament site;

3) Exhibitions;

4) Class B, C, and D tournaments (which include those limited to contestants other than Class A and those in which a Class A player may compete with a Class B, C, or D player as a partner.)

c. All applications for sanction must be received by the Chairman of the ABA Tournament Sanction Committee at least one month prior to the opening date of the tournament for which a sanction is requested. A penalty of \$1.00 shall be assessed for all late sanction applications.

2. Sanction Procedure:

a. Plans for the season's tournament play should be developed and sanctions should be requested as early as possible. (See listing of Regional Sanction Chairmen, Appendix). Plans that affect more than one association in a general area from which tournament entries may be expected should be coordinated directly between all associations having jurisdiction within that area.

b. To avoid serious conflicts of dates, sanction for each tournament shall be procured in accordance with the following:

- 1) Local tournaments are subject to district or regional sanction;
- 2) District tournaments are subject to regional association sanction;
- 3) Regional association tournaments are subject to ABA sanction;
- 4) Special tournaments are subject to ABA sanction.

3. Junior tournaments and championships shall be sanctioned in the same manner as adult tournaments and championships and the same ABA policies shall apply.

4. In the event proposed dates clash with any tournament already sanctioned, or if the proposed tournament conditions are considered to be undesirable in the interests of the game by the association responsible for the sanction, the tournament committee concerned shall be advised accordingly and recommendations advanced.

a. Failure to comply with the final decision of the association concerned shall obligate the tournament committee concerned to submit the matter to the Chairman of the ABA Sanction Committee for consideration.

b. If the official objection to the tournament is confirmed, the players who competed in the unauthorized tournament shall be suspended from further competition in any tournament.

V. ACTUAL CONDUCT OF TOURNAMENT

A. Player Eligibility:

1. No player shall be eligible to compete in any sanctioned tournament:

a. unless he or she is an amateur according to the rules of the ABA (see page 14) or the rules of the national association, other than the ABA with which the player is affiliated, and

b. except as the Tournament Committee shall otherwise determine in particular cases, unless he or she either is:

- 1) a member of a club in good standing affiliated with the ABA or with the IBF, or
- 2) an individual member of the ABF, or
- 3) in the case of a Junior, is sponsored by one of the above.

2. It is the recommendation of the ABA that the age limits which apply to the National Junior

Championships be followed in all junior championships and tournaments.

3. No ABA member shall knowingly participate in any tournament promoted by an ABA or IBF club or organization unless it has been sanctioned by the ABA or approved by the IBF.

4. Players violating the above regulations shall be ineligible to receive a ranking or to participate in any sanctioned or approved tournament for a period of one year from the date of the violation, subject to review of the Amateur Status Committee.

B. The ABA Match Scheduling (following pages) system of allocating time of play and courts to players should be used in all championships and tournaments.

C. If a challenge cup is not played for in any one season, the player who won it the previous year shall be deemed to have won it that season.

D. Officiating: When an umpire is officiating, the laws of the game shall be enforced by him and in his judgement. In the absence of an umpire, the players concerned shall carry out the rules and if a violation be claimed by one side and not acknowledged by the other, a "let" shall be allowed. Umpires are recommended for all semi-final matches, and both umpires and linesmen shall be provided for all final matches in any championship tournament. (See: Referees, Umpires and Linesmen, pp. 32-34)

D. Tournament Results of all sanctioned tournaments shall be sent to the ABA Sanction Chairman who will distribute them to the proper persons, i.e.:

1. The regional tournament representative in the area in which the tournament was held;
2. The official publications of the ABA;
3. Junior Activities Chairman of the ABA if any juniors are entered.

ABA & IBF TOURNAMENT REGULATIONS

THE DRAW

1. The draw for all events at Open Tournaments shall be made in the manner set out below, and no dummy entry in singles or dummy pair in doubles may be included in the draw of any championship event. There shall be no alteration in the published draw of any championship event unless permitted under exceptional circumstances by the tournament committee, but no such alteration shall be allowed in singles events, nor in a doubles event if two or more pairs already entered should object.

NOTE.- The purpose of allowing any alteration is to enable a competitor to have a substitute partner in a doubles event if his original partner is prevented from playing through illness, injury, or other unavoidable hindrance. The purpose of allowing alterations is not so that any fresh entries may be introduced.

Immediately any request for alteration is received, competitors in the event concerned shall be acquainted thereof by the Referee by means of a notice prominently displayed on the notice board (if any) and/or in the changing rooms. They shall be given reasonable time to lodge objections which shall be received in confidence.

2. Under no circumstances shall any player be permitted to compete more than once in the same event at any tournament.

3. In no event shall the draw be arranged, except that seeding in championship events shall be permitted under the conditions set out below.

4. The draw shall be conducted as follows:-

When the number of playing units is 4, 8, 16, 32, 64, or any higher power of 2, they shall meet in pairs in the order drawn, as in the following diagram:-

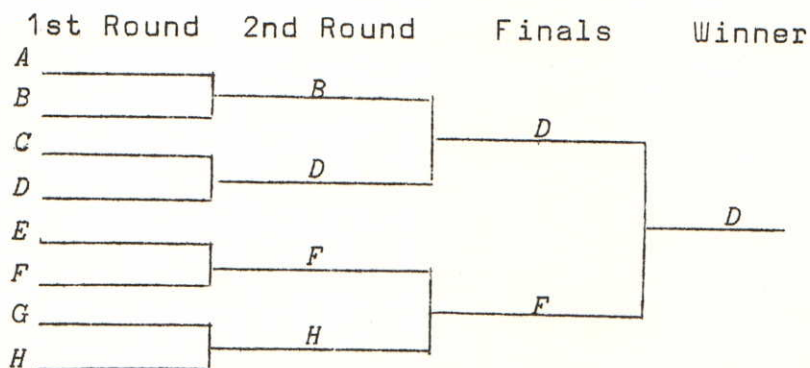

When the number of playing units is not a power of 2, there shall be byes in the first round. The number of byes shall be equal to the difference between the next highest power of 2 and the number of playing units. The

byes, if even in number, shall be divided, as the names are drawn in equal proportions at the top and bottom of the list, above and below the pairs; if uneven in number, there shall be one more bye at the bottom than at the top.

Example - With 19 playing units there will be $32 - 19 = 13$ byes, 6 at the top and 7 at the bottom of the list, and 3 matches in the first round, 8 in the second, 4 in the third, etc.

Example - with 9 playing units there will be $16 - 9 = 7$ byes, 3 at the top, and 4 at the bottom, and one match in the first round, see below.

1st Round 2nd Round 3rd Round Final Winner

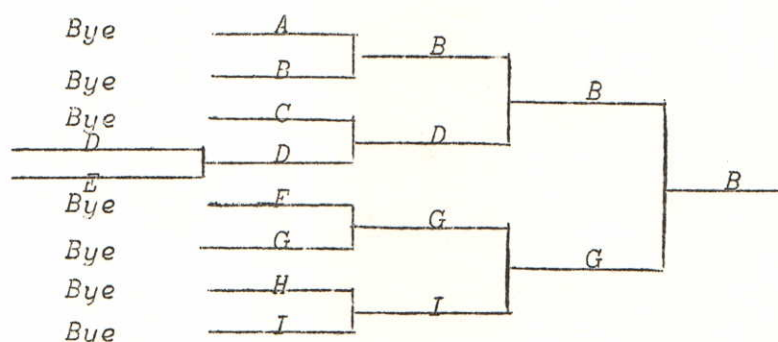

- With 5 playing units there will be 1 bye at the top and 2 byes at the bottom.
 With 6, 1 bye at the top and 1 bye at the bottom.
 With 7, 1 bye at the bottom.
 With 8, no byes.
 With 9, 3 byes at the top, and 4 byes at the bottom.
 With 10, 3 byes at the top and 3 byes at the bottom.
 With 11, 2 byes at the top and 3 byes at the bottom.
 With 12, 2 byes at the top and 2 at the bottom.
 With 13, 1 bye at the top and 2 at the bottom.
 With 14, 1 bye at the top and 1 at the bottom.
 With 15, 1 bye at the bottom.
 With 16, no byes.
 And so on with larger numbers in like manner

SEEDING THE DRAW

5. At any open tournament, the prospectus of which gives due notice thereof, the draw in the level events may be arranged or "seeded" subject to the following restrictions:-

- (a) Entries to the number of eight, and no more, may be seeded by lot into separate eighths of the draw of an event comprising at least 32 entries; and, similarly, in events comprising fewer entries, four

may be seeded in the case of 16 or more entries, and two in the case of any smaller number, and they shall be drawn by lot into separate quarters, or halves of the draw, as the case may be.

- (b) The entries to be seeded shall be selected by the committee as being, in its opinion, the best in the event.

6. The seeded entries shall be drawn as follows:-

- (a) If two are to be seeded, numbers 1 and 2 shall be drawn by lot; the first drawn shall be placed at the top of the upper half and the second at the bottom of the third quarter.
- (b) If four are to be seeded, numbers 1 and 2 shall be placed as above; numbers 3 and 4 shall be drawn by lot and the first drawn shall be placed at the top of the second quarter; the second shall be placed at the bottom of the third quarter.
- (c) If eight are to be seeded, numbers 1, 2, 3 and 4 shall be placed as above; the remainder shall be drawn by lot and placed in the upper half, at the top of the eighths not already occupied and in the lower half, at the bottom of the eighths not already occupied. (See Example below).

7. Any two entries from any country which shall be seeded shall be drawn in separate halves of the draw, and any three or four entries from any one country which shall be seeded shall be drawn in separate quarters of the draw. Note: In the United States, Regions should be considered as countries in this regard.

8. In addition to the seeded entries, in the case of only two entries from any one country, they shall be drawn in separate halves of the draw, and not less than the four best entries from one country, but not more than eight, shall be drawn in separate quarters or eighths, as the case may be. Note: Again treat states or regions in the United States as countries in this matter.

EXAMPLE OF SEEDED DRAW

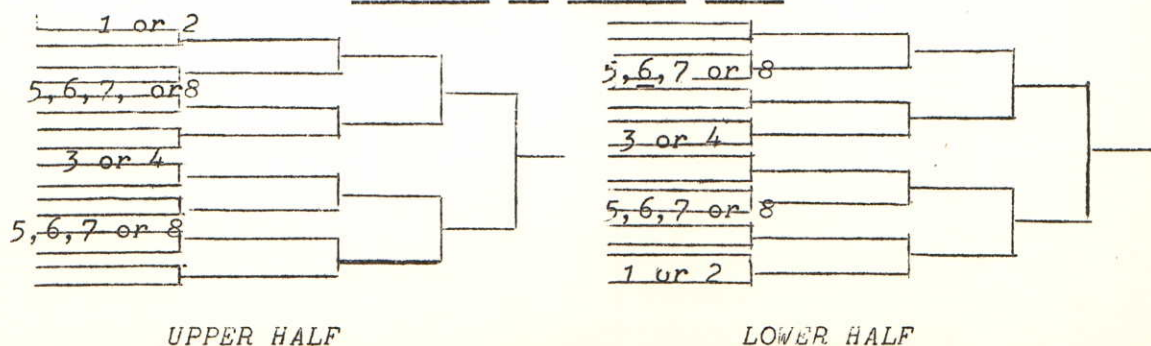

NUMBERING MATCHES

Matches Numbered on Draw Sheets - 1 through 232

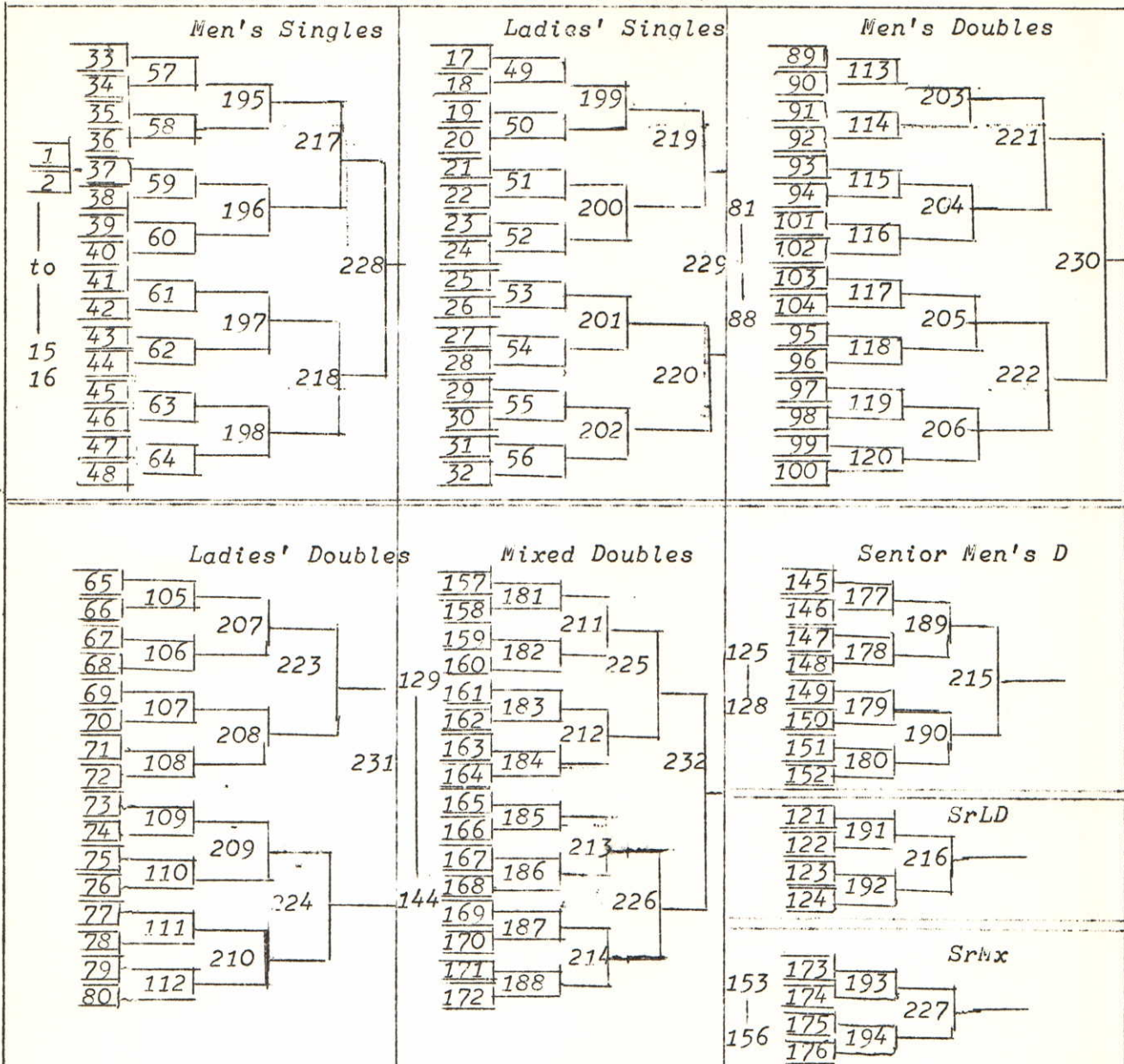

Exhibit 2A

SCORE SHEETS

TWO TYPES

Event ___ Round ___ Time ___ # ___

Event ___ Flight ___ Time ___ Match# ___

Players _____ vs _____

_____ vs _____

Winner from # ___ vs

Court ___ Date _____

Winner from # ___

Names

Names

1st game _____

_____ 123456789101112131415161718

2nd game _____

_____ 123456789101112131415161718

3rd game _____

_____ 123456789101112131415161718

Results Posted Umpire

Results Posted Umpire

4. Prepare Schedule Sheets. (See Exhibit 3 for completed sample)
- Allow one vertical column for each court and one horizontal line for each half-hour (for a two day tournament 45 minutes may be better) interval.
 - Number sheets according to the number of matches to be played as indicated on the Draw Sheets. Allow for one unscheduled half-hour or 45 minutes every 7th or 8th period taking each court in succession.
 - Determine the number of matches to be played prior to the quarter-finals by subtracting 8 from the number of entries in each event.
 - Determine the number of half-hour, or 45 minute periods necessary to have the entire tournament reach the quarter-finals by using the answer to 4.c. above, divided by the number of available courts. This will give an indication of the time the tournament should start so as to finish at a reasonable time.

Exhibit 3

SCHEDULE SHEETS

Symbols used: MS, LS, MD, LD, Mx, SrMD, SrLD, SrMx --- Events

MS 33 --- Start of Men's Singles event

x --- Completion of round for event

. --- Open court

First Day					Second Day				
Courts					Courts				
Time	1	2	3	4	Time	1	2	3	4
AM					AM				
9:00	MS 1	2	3	4	9:00	MD89	90	91	92
9:30	.	5	6	7	9:30	.	93	94	95
10:00	8	9	10	11	10:00	96	97	98	99
10:30	12	.	13	14	10:30	100	.	101	102
11:00	15	16x	LS17	18	11:00	103	104x	LD105	106
11:30	19	20	.	21	11:30	107	108	.	109
12:00	22	23	24	25	12:00	110	111	112x	MD113
PM					PM				
12:30	26	27	28	.	12:30	114	115	116	.
1:00	29	30	31	32x	1:00	117	118	119	120x
1:30	.	MS33	34	35	1:30	.	SrLD121	122	123
2:00	36	37	38	39	2:00	124x	SrMD125	126	127
2:30	40	.	41	42	2:30	128x	.	Mx129	130
3:00	43	44	45	46	3:00	131	132	133	134
3:30	47	48x	.	LS49	3:30	135	136	.	137
4:00	50	51	52	53	4:00	138	139	140	141
4:30	54	55	56x	.	4:30	142	143	144x	.
5:00	MS57	58	59	60	5:00	SrMD	146	147	148
5:30	61	62	63	64x		145			
7:00	LD65	66	67	68	5:30	149	150	151	152
7:30	.	69	70	71	7:00	SrMx	154	155	156x
8:00	72	73	74	75		153			
8:30	76	.	77	78	7:30	.	Mx157	158	159
9:00	79	80x	MD81	82	8:00	160	161	162	163
9:30	83	84	.	85	8:30	164	.	165	166
10:00	86	87	88x	.	9:00	167	168	169	170
					9:30	171	172x	.	SrMX173
					10:00	174	175	176x	

Third Day					Last Day		
Time	Courts				Time	Event	Match
	1	2	3	4			
9:00AM	SrMD177	178	179	180x	1:15	SrMx	227
9:30	.	Mx181	182	183	2:00	MS	228
10:00	184	.	185	186	2:45	LS	229
10:30	187	188x	.	SrMD189	3:30	MD	230
11:00	190x	SrLD191	192x	.	4:15	LD	231
12:30	SrMx	193	.	194x	5:00	Mx	232
1:15	MS195	196	197	198x			
2:00	LS199	200	201	202x.			
2:45	MD203	204	205	206x			
3:30	LD207	208	209	210x			
4:30	Mx211	212	213	214x			
<u>Semi-Finals</u>		<u>Event</u>	<u>Matches</u>				
6:30		SrMD	215	216			
7:15		MS	217	218			
8:00		LS	219	220			
8:45		MD	221	222			
9:30		LD	223	224			
10:30		Mx	225	226			

5. Enter match numbers through quarter-finals on Operations Sheet using symbols to mark start and conclusion of each round of each event on the Schedule Sheet, conclusion of first and second round, match on the court or completed, match winner, and the score. (See Exhibit 4)

Exhibit 4

OPERATIONS SHEET

TIME	COURT # 1	COURT # 2	COURT # 3	COURT # 4
9:00	on court MS-1 Anderson vs Restel	completed MS-2 Names	Names MS-3	Names MS-4
9:30	OPEN	Names MS-5	Names MS-6	Names MS-7

10:00 --- Continue to make up Operations Sheet according to Schedule Sheets (Exhibit 3)

4:00	Winner 19 LS-50 vs Winner 20	etc. LS-51	etc. LS-52	etc. LS-53
4:30				open

Continue in this way until end of the tournament

6. Set up schedule for the 2 concluding rounds of all events, i.e. semi-finals and finals.
7. Complete Control Sheet (Exhibit 5) with every possibility of winners of each round and each event.
8. Make up Player's Schedule Card from the Control Sheet and mail to players well in advance of tournament dates. (Schedule Card -- Exhibit 6)

Exhibit 5

CONTROL SHEET*

1st Day Players	Morning						Afternoon			
	9:00	9:30	10:00	10:30	11:00	11:30	12:00	12:30	1:00	etc
Abbott,				MS						
Anderson	MS									
Ash							LS			
Parsons		MS								MS

* Similar sheets should be made for each day of play or time for remaining matches. Sample does not include all names. Sheets must be filled in with names of all contestants.

Exhibit 6

SCHEDULING CARDS

NAME _____		PARTNERS _____								
Number Events Entered _____		_____								
(Tournament) _____		_____								
Date _____		Place _____								
	Singles		Doubles		Doubles		Doubles		Doubles	
	Court	Time	Court	Time	Court	Time	Court	Time	Court	Time
Your 1st match is										
If you win you play again at										
Next play										
Players must be at the court and ready to play at the scheduled time. If more than 5 min. late, the match will be defaulted.										

9. Record keeping of the tournament results needs the following 5 items: 1) Draw Sheets; 2) Schedule Sheets; 3) Operation Sheets; 4) Match or Score Sheets (Exhibit 2A); 5) Large Draw Sheets for Bulletin Board so players and spectators may see play progress. Official results from the Score Sheets are entered on the Tournament Manager's Official Draw Sheet and on the Bulletin Board sheets as play progresses.

#

APPENDIX

a.
SAMPLE

APPLICATION FOR MEMBERSHIP IN THE AMERICAN BADMINTON ASSOCIATION
CLUB OR ASSOCIATION OR GROUP

Date: _____

To the ABA Board of Directors

We, _____, President

and _____, Secretary

being duly authorized for the purpose, hereby apply, on behalf

of the _____ Badminton (Club
(Group
Association

for membership in the American Badminton Association. We will observe and be bound by the rules of the Association.

Signatures _____, President

_____ Address

_____ Address, Secretary

Number of members _____

Place and time of play _____

* * * * *

Circle the type of membership for which application is being made.

Regional Association = four or more clubs @ \$1.75 per person.

Independent Badminton Club = six or more members @ \$1.75 per person

Other Organization, i.e., School, YMCA, Camp, etc. @ \$10.00

Make Checks payable to AMERICAN BADMINTON ASSOCIATION and mail to

Mrs. Virginia B. Lyon
ABA Administrative Secretary
1330 Alexandria Drive
San Diego, California 92107

APPLICATION FOR INDIVIDUAL MEMBERSHIP ENROLLMENT IN THE AMERICAN
BADMINTON ASSOCIATION

American Badminton Association
1330 Alexandria Drive
San Diego, California 92107

Gentlemen:

In order to play in ABA sanctioned tournaments,
To have my tournament record considered for ranking,
To receive the official ABA magazine, BADMINTON USA, as well as
the official ABA Bulletin,
To help promote badminton development in the USA,
To help support USA teams in international competition,
To support youth fitness and a lifetime sport for all ages,
I hereby apply for Individual Membership in the ABA and enclose
\$5.00 as my dues for the current season, or \$100.00 for a
Lifetime Membership*

Please Print or Type All Information

Mr.
Mrs.
Miss

Last Name First Name Initial

Address: -----
Number Street City State Zip

(signature)

* Make \$5.00 check payable to the ABA
Make \$100.00 check payable to the U.S. Badminton Education
Foundation

REGIONAL SANCTION CHAIRMEN68-69 SEASON

<u>Region</u>	<u>Chairman</u>	<u>Phone No.</u>
1	Don Lumsden 64 Pond Street Needham, Massachusetts 02192	617/444-0692
2	William Parsons 3508 Ft. Roberdeau Altoona, Pennsylvania 16601	814/943-9005
3	Taylor Caffery 1805 NBC Building New Orleans, Louisiana 70112	504/522-5601
4	Harold Deeman 2902 W. 39 th Place Chicago, Illinois 60632	312/LA-31534
5	Edward Stuart Friendswood, Texas 77546	713/482-7850
6	Joe Alston 989 Hillside Terrace Pasadena, California 91105	213/799-3627
6	Cliff Mountain 1863 23rd Avenue, East Seattle, Washington 98102	206/EA-31859

1 Lumsden	2 Parsons	3 Caffery	4 Deeman	5 Stuart	6 Alston (So.) Mountain (No.)
Maine N.Hampshire Vermont Mass. R.Island Conn.	New York New Jersey W.Virginia Penn. Delaware Maryland D.C.	Virginia N.Car. S.Car. Tenn. Georgia Florida Alabama Miss. Louisiana Arkansas	Ohio Michigan Indiana Illinois Kentucky Wisconsin Minnesota Iowa Missouri	Texas Oklahoma Kansas Nebraska S.Dakota N.Dakota New Mexico Colorado Wyoming Utah Montana	California Nevada Arizona Hawaii Oregon Washington Idaho Alaska
Conn.Badm. Assoc. Mass.Badm Assoc N.Hamp Badm Assoc R.Island Badm Assoc	Del.Valley Badm Assoc Md. Badm Assoc Metro.Badm. Assoc W.N.Y.Badm Assoc	Southern Badm Assoc	Midwest Badm Assoc	South- western Badm Assoc	N.Calif. Badm Assoc S.Calif. Badm Assoc Oregon Badm Assoc Washington Badm Assoc

ABA Sanction Chairman: Cletus Eli, 6303 S. Linden Rd., Swartz Creek
Michigan 48473

TOURNAMENT ENTRY BLANK:-SAMPLE

TOURNAMENT NAME		
Month	Days	Year
DATE		

CLASS OF TOURNAMENT: i.e. "A" & CONSOLATION, "B" & CONSOLATION

SPONSORED BY:

SANCTIONED BY:

CONDUCTED BY:

TO BE PLAYED AT:

TOURNAMENT COMMITTEE:

ELIGIBILITY & RANKING: Example- "A" and CONSOLATION TOURNAMENT-
All players are eligible regardless of ranking.

"B" and CONSOLATION TOURNAMENT-Only players who have been ranked "B" or "C" in an event will be eligible to compete in that event. Eligibility of any nonranked players will be determined by the tournament committee.

NOVICE FLIGHT - This flight reserved for unranked players and those who may be ranked "C", but have made little progress in the one or two tournaments entered. Eligibility will be determined by the tournament committee.

ENTRY DEADLINE: Entries must be postmarked by midnight, _____
_____ or they will not be placed in the draw.

ADDITIONAL INFORMATION: Phone number of Tournament Chairman

CONDITIONS OF THE TOURNAMENT

1. The Tournament is open to all amateurs.
2. The Tournament will be conducted in _____ flights: "A" Flight and Consolation, "B" and Consolation, Novice
3. Players losing first round match in either "A" or "B" Flights will then play in Consolation round of that Flight with the exception of players who have been seeded by the Draw Committee.
4. Trophies will be awarded to all finalists in "A" Flight and "B" Flight and to winners of "A" Consolation, "B" Consolation, and Novice Flight.

Return Address
Tournament Chairman

Stamp

Name and Address to whom
Entry is being sent

5. The Tournament Committee will have the right to cancel any event in case there are insufficient entries.
6. The Tournament Committee reserves the right to alter the terms or dates of the Tournament and to reject the entry of any player for grounds which it may deem advisable.
7. Players must be ready to play at the time set for match or it will be necessary to default them unless delayed by another match. The 5 (15) minute default rule will be strictly enforced.
8. Players winning a match by default will be referred to the Tournament Committee for next match. A default on the first match does not eliminate the player from the Consolation Flight, should he lose the next match.
9. Decisions of Official Referee shall be final.
10. Umpires will be provided for every match.
11. Players are requested to wear all white clothing while on courts.
12. Play will be governed by the rules of the American Badminton Association.
13. An entry blank (or facsimile) must be sent for each individual entrant, accompanied by appropriate fee or the entry will not be placed in the draw.
14. Substitution of partners will not be allowed after the team has started the first match.
15. The Tournament Committee will make every effort to secure partners for those who so desire. If partner is not found, fee for the event will be refunded.
16. Players will be notified by mail as to times of their matches. Times of all matches will be posted on draw sheets at the tournament.
17. Players must be available for play from _____ P.M. Friday and from _____ A.M. Saturday if so scheduled.
18. Players must purchase tokens for shuttles before matches. One token per person will be required for every shuttle used in a doubles match; two tokens per person for every shuttle used in a singles match. Tokens will sell for 5/\$1.00 and will be collected by the Umpire before the match. (Note: This is a method that has kept tournaments from going in the red since the increase in shuttle costs.)

MAIL ENTRIES TO:

Tournament Chairman, Address

MAKE CHECK PAYABLE TO:

ENTRY FEES:

ENTRY BLANK (Limit - Three Events)

Name _____ Phone _____

Address _____

City _____ State _____ Zip _____

Club _____ School _____

Men's Singles	A _____	B _____	Total fee enclosed \$ _____
Ladies' Singles	A _____	B _____	
Men's Doubles	A _____	B _____	Partner
Ladies' Doubles	A _____	B _____	Partner
Mixed Doubles	A _____	B _____	Partner

SAMPLE

AMERICAN BADMINTON ASSOCIATION
ACKNOWLEDGEMENT OF PERPETUAL TROPHY FORM

Receipt is hereby acknowledged for the Perpetual Trophy for

to be held by the undersigned, subject, in all respect to the regulations of the ABA (as outlined below) applicable to the custody, care, engraving, and return thereof to all of which the undersigned agrees to conform.

Date _____ Signed _____

Address _____
Street City State Zip

Date _____ Signed _____

Address _____
Street City State Zip

REGULATIONS

1. The winner of the trophy shall be responsible for the safekeeping of the trophy.
2. The name(s) of the winner(s) and the year shall be engraved in the proper place and in full conformity with the established design. Upon receipt of the bill, the ABA will refund the payment on the basis of _____ cents a letter for _____ letters.
3. The winner(s) of the trophy shall be permitted either to personally transport the trophy to his or her home (provided the trophy is not taken outside the USA), or have the trophy forwarded to such destination without expense to the ABA.
4. The party responsible for each trophy shall deliver it in its shipping case, or cause it to be delivered _____
Shipping at least one month in _____ Type of
advance of the succeeding Championships to an authorized recipient at the place of such Championships. Upon receipt of the shipping bill by the ABA Administrative Secretary, the sender will be reimbursed.

NOTE: This form must be completed in triplicate. Two copies are to be retained by the ABA Administrative Secretary, one copy to be retained by the trophy winner.

(12/10/68)

INDEX

- Administrative Secretary, 11,
12,13,15,18,e
- Amateur Status (Standing), 7,
14,22,39,43-44,46
- Amendments, 8,9,10
- Appeal, 8,15
- Appendix, a-e
- Appreciation Award, Players, 21
- Associations, 2,3
- Awards, 16-21
- Badminton USA, 12
- Ballots, 6,10; Davidson, 20
- Board of Directors, 3
- Bulletin, ABA, 11-12
- Championships, 16,17-18,20,21A
22,23,25-26,30-42,43,45,47;
Shuttles for, 36-37
- Clubs, 3,4,5,6,9,13
- Committees, ABA, 6-8; Chairmen
for, front page
- Constitution, 1-10
- Davidson, Ken, 18-20
- Directors, 3,4,5,11, front page
- Draw, 23,47,48-50
- Dues, 5-6,13,a,b
- Elections, 10
- Eligibility, players, 21A,22-23,
24,25,26,29,38,39-41,45-46;
for awards, 19,20
- Emblems, ABA, 16-17
- Entry Cards, 25,39,d-d1
- Executive Committee, 4,5,6,10,
11,17
- Exhibitions, 38-39
- Expenses, tournament, 41-42
- Front page
- Guides, Rules & Regulations, front
- Handbook, ABA, 8,11,12
- Helms Hall of Fame, 20-21
- Individual Memberships, 2,5,6,10
13,b
- International Badminton Federation,
IBF, 1,11,12,14,21-23,47-49
- Invitations, foreign players, 22
- Junior Activities, 8,17-18,16,19-20,
24-25,25-26,27,28,29,31,40,
44,46
- Laws of Badminton, 11,23
- LCA, contract with, 35
- Linesmen, 34
- Match Scheduling, ABA, 50-54
26,40,46
- Meetings, 9-10
- Membership, ABA, 1,2,3,7,13,a-b
- National Championships, 21A,23
25-26,36-37,39-42,47-48,48-49,
50-54,e
- News, National Badminton, 7
- Nominations, 8,9-10
- Objectives, ABA, 1
- Official Publication, 8-9,11,12
33,46
- Officers, ABA, front page, 5
- Pins, ABA, 13,17
- Personnel, ABA, 11
- Players, foreign, 21-23; travel
expenses 41-42; eligibility,
26,40
- Publications, ABA, 11-13
- Players' Appreciation Award, 21
- Ranking, 7,27,28-31; 1968-1969
lists, 30-31
- Referees, 32-33
- Regions, ABA 3-4
- Reports, 8,13
- Royalties, 12
- Rules Book 12; committee, 6
- Seeding, 23,48
- Service Court Judge, 34
- Shuttlecocks, 7,22,35-37
- TV, 42
- Thomas Cup, 7,13,22,24,27
- Tournaments, 25,38,39-42,45,46,
47-48,48-49,50-54
- Traveling expenses, 39,41-42
- Trophies, 17,18-20,21,e
- Uber Cup, 8,13,17,22,24
- Umpires, 32-33,46
- Vacancies, Directors, 4
- Voting, 5-6,8,9,10

ADDITIONS AND CORRECTIONS TO THE 1967-1968 ANNUAL REPORT AND
CLUB ROSTER

Page 8: New Hampshire --- New President: Peter Gauthier
Oregon --- New President: Steve Prothero
New Secretary Chris Janz

Club Roster

- Page A: Hartford B.C --- Zip-CT 06118
Milford B.C ---- Zip-CT 06468
- Page C: Dilwyne Club --- New President: S. Wm Bender
Tom Kip, new Address 5 Stone's Throw Road
3037 Midvale Ave., Zip 19129 Wilmington, DE 19803
- Page D: Homeland Club --- Robert Brooks new address
6404 Blenheim, Baltimore, MD 21212
- Page H: Sec. Miss Pamela Appletpm - address
% Anderson Apartment 4C, 51 E 73rd Street NY 10021
Metro Life Insurance Co. Club --- Correct address
for Wm. Green: Demarest (not Benerast)
Miller Place -- Zip correction 11764
- Page L: Skokie Club --- New President: Bill Kellogg
3017 Iroquois Rd., Wilmette, IL 60091
West Detroit Club --- Name Change and new President
Now: Detroit Metropolitan Badminton and Tennis Club
Victor Pritula, President: 9585 Westwood St.,
Detroit, MI 48228
- Page M: New Hampshire Association new officers:
Pres: Peter Gauthier, 2 Topsfield Dr. Westwood Park,
Nashua, NH 03060
V.P. Norval Lessels, 68 Broadway, Concord, NH 03301
Sec: Mrs Maurice (Elaine) Hoyt, 38 Amesbury Rd.
Contoocook, NH 03229
Treas: Edward Balch, 166 Dewey St., Manchester, NH 03103
- Page O: Oregon Association New Officers; 97301
Pres: Steve Prothero, 3856 Manor Dr., NE, Salem, OR /
V.P. Gordon Noraine, 423 SE Gilham Ave., Portland
OR 97215
Sec: Chris Janz, 155 E. 34th Place, Eugene, OR 97405
Treas: Al Peters, 3764 S Lakeview, Lake Oswego
OR 97034
Tournament Chair. Joe Griffith, 8705 S White Court
Portland, OR 97225
- Page U; New addresses: Charles Holbrook, 1114 Greencove,
Richardson, TX 75080
Virginia Hicks, Box 3717 TWU Station, Denton, TX 76204
- Page W: Add new Club --- Charleston Racquets Club:
President: Edwin Shuffle, 1523 Bedford Road
Charleston, WV 25314
- Page 24: Add New Direcotrs: Region 1 -- Lester Hilton,
15 Tanglewood Dr., Cumberland
RI 02864
Region 6 -- Phil Janz, 155 34th Place East
Eugene, OR 97405
Correct address for Virginia Hicks, Region 5
Box 3717 TWU Station, Denton, TX 76214
- Page 25: Ranking and Sanction Committee --- Add Regional Sanction
Chairmen: Region 1-Don Lumsden; Region 2 Wm Parsons
Region 3-Taylor Caffery; Region 4-Harold Deeman
Region 5-Ed Stuart; Region 6-Joe Alston and
Cliff Mountain
- Page 26: Badminton USA Committee--- Delete: E.C. French, Mary Lee
Masterson, Richard Roberts, and Sharon Whittaker
Add: IBF Reporter to Mrs. Judy Hashman
Junior Assistants: Gaye Gerzine and Cindy Young
- Roster of Personnel
- i -- Correct addresses: Appleton:% Anderson Apt. 4C, 51 E. 73rd
New York, NY 10021
Breckell: Zip number 90039
Brooks: 6404 Blenheim Rd., Zip 21212
- ii Hicks: Box 3717 TWU Station, Denton, TX 76204
Holbrook: 1114 Greencove, Richardson, TX 75080
- iii Kip: 3037 Midvale Ave., Zip 19129 70803
- iv Poole: P.O. Box 21451 University Station, Baton Rouge, LA /
vanPraag, Richard: 1760 Loma Vista